

Model #

2403GACg

2403CAFg

McKenzie Lateral File Cabinet

GAC = Glazed Antique Cherry finish

CAF = Caffè finish

Assembly Instructions

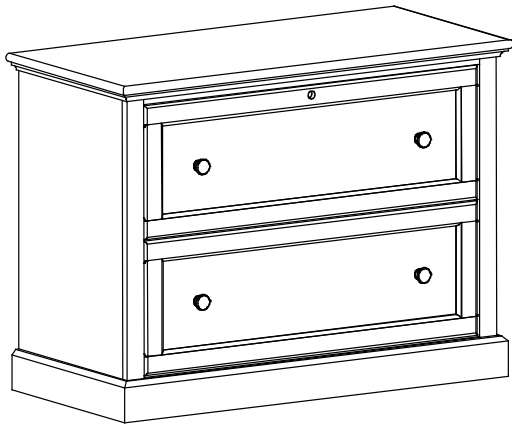

Thank you for allowing us to help you furnish your home. We are certain you will be delighted with your new furniture for many years to come.

IMPORTANT NOTES:

- For normal household use only. *Not* recommended for commercial use.
- Use a protective pad when you use the top of this piece as a writing surface.
- Do not climb, sit or stand on this piece of furniture.
- Do not overload the drawers.
- Place heaviest items in the bottom drawer.
- Unload items before you move this unit.
- This assembly requires two people.

WARNING

Serious or fatal crushing injuries can occur from furniture tip-over. Use of tip-over restraints may only reduce but not eliminate the risk of tip-over.

To help prevent tip-over:

- Place heaviest items in the bottom drawers.
- Unless specifically designed to accommodate, do not set TVs or other heavy objects on top of this product.
- Never allow children to climb or hang on drawers, doors or shelves.
- Never open more than one drawer at a time.
- Do not defeat or remove the drawer interlock system.

Warning: At least one tipping restraint kit was included with your piece of Whittier Wood Furniture. When you receive your furniture, be sure to find and properly install the tipping restraint(s). If you cannot locate the restraint(s), please contact us immediately for replacement.

Drilling, sawing, sanding or machining wood products can expose you to wood dust, a substance known to the state of California to cause cancer. Avoid inhaling wood dust or use a dust mask or other safeguards for personal protection.

For more information go to: www.p65warnings.ca.gov/wood

This product can expose you to chemicals, including formaldehyde, which are known to the State of California to cause cancer.

For more information go to: www.p65warnings.ca.gov/furniture

DESIGN SUBJECT TO CHANGE WITHOUT NOTICE.

CUSTOMER SERVICE

If you ever have questions about your furniture, please do not hesitate to contact us. In the unlikely event you need a replacement part; we can make those parts available through an authorized Whittier Wood Furniture dealer. If you cannot order replacement parts through your dealer, please contact our customer service department.

Hours: Our friendly customer service staff can be reached:

Monday-Friday 8:00 a.m. to 5:00 p.m. (Pacific Time).

You may leave a message 24 hours a day, seven days a week.

Customer Service: 800-653-3336 • **Outside the U.S.:** 541-687-0213

Fax: 541-687-2060 • **Email:** info@whittierwood.com



P.O. Box 2827
Eugene, OR 97402 USA

Production Code:











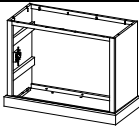



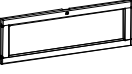



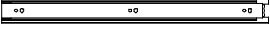

VN

10/17

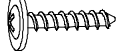
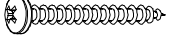

2403GACg 2403CAFg McKenzie Lateral File Cabinet

Parts List

Please identify the parts and check that quantities received match those on this list.
If you need to replace a part, refer to the following letter and part name.

Part	Description		Quantity
Ag	Case Assembly		1
B	Top Assembly (attached)		1
C	Back (attached)		1
D	Drawer (inserted)		2
E	Upper Drawer Face (installed)		1
F	Lower Drawer Face (installed)		1
G	Drawer Divider (attached)		4
H	Lock (attached)		1
I	#6 x 5/8" Philtruss Screw (inserted)		16
J	H. D. 16" Drawer Slides (pre-installed sets)		2
K	#6 x 3/4" Philtruss Screw (inserted)		23
L	#6 x 1/2" Philtruss Screw (inserted)		22
M	Knob (attached)		4
Nf	#8 x 1-1/2" Machine Screw Tuscan (installed)		4
O	Plastic File Rail (attached)		8
Pf	#8 x 7/8" Black Lo-Profile Screw (inserted)		16
Q	#8 x 1-1/4" Pan Head Screw (inserted)		11
S	#8 x 1-5/8" Black Screw (inserted)		8
U	#8 x 2-3/4" Black Screw		3
W	Small Adjustable Glide (installed)		2
X	Tack Glide (inserted)		2
Y	1/4" Insert Nut (inserted)		2
ZF	#8 x 1-3/8" Lo-Profile Screw (inserted)		6

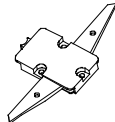
2403GACg 2403CAFg McKenzie Lateral File Cabinet
Parts List

Part	Description	Quantity
ZG	Anti-Tip Snapper (attached) 	1
ZH	Drawer Clip (attached) 	2

2403GACg 2403CAFg McKenzie Lateral File Cabinet

Assembly Instructions

Tools Required: Phillips Screwdriver, Pencil.

1. This piece of furniture includes a drawer interlock system allowing only one drawer to be open at a time. This is a safety feature to reduce the risk of tip over. Do not defeat or remove the drawer interlock system. Drawers need to be removed to reconfigure the file drawers and anchor the file cabinet to reduce the risk of tip over.
2. When removing drawers from furniture featuring the Anti-Tip Drawer Interlock System it is important that the drawer be installed back in its original location. Numbers and letters are stamped on the back of the drawers. Stamping sequence starts at the bottom, moves to the top. Drawer back stamping example:

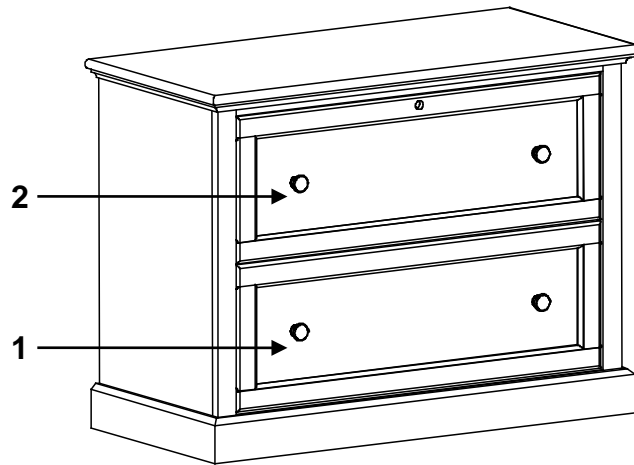

Fig. 2

3. To remove a drawer from the Case (Ag), pull up on the left Drawer Release Lever while pushing down on the right Drawer Release Lever and pull out the drawer. See Figures 3 and 3a. Note where each drawer came from to make sure you place them back into their correct positions.

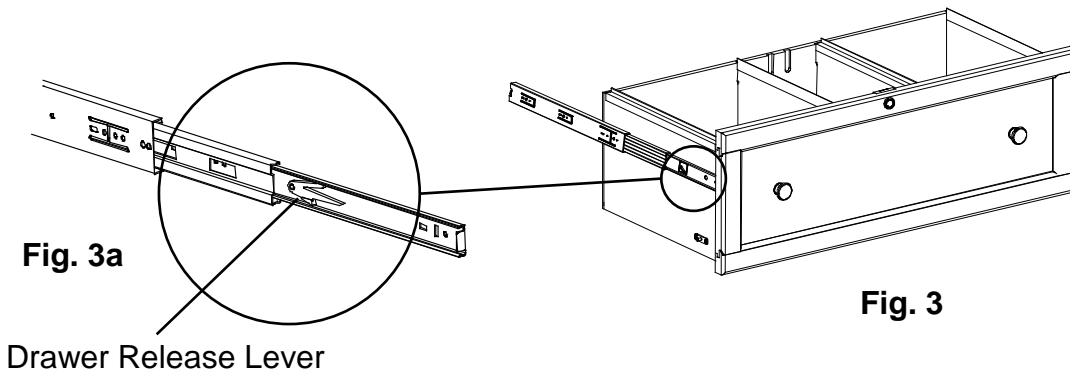

Fig. 3a

Drawer Release Lever

Fig. 3

2403GACg 2403CAFg McKenzie Lateral File Cabinet

Assembly Instructions

4. Remove the upper/second drawer first. When you remove this drawer, the upper arm on the Anti-Tip Snapper for that side will be pulled forward. See Fig. 4d. As long as this arm is angled toward the front of the case, you cannot remove the lower/first Drawer (D). Move the upper arms of the Anti-tip Snapper to the unlocked position as shown in Figure 4e. You can then remove the lower/first drawer as shown in Step 3. To reinstall the drawers, install the lower/first Drawer then move the upper arm of the Anti-tip Snapper to the forward locked position. Now you can reinstall the upper/second Drawer.

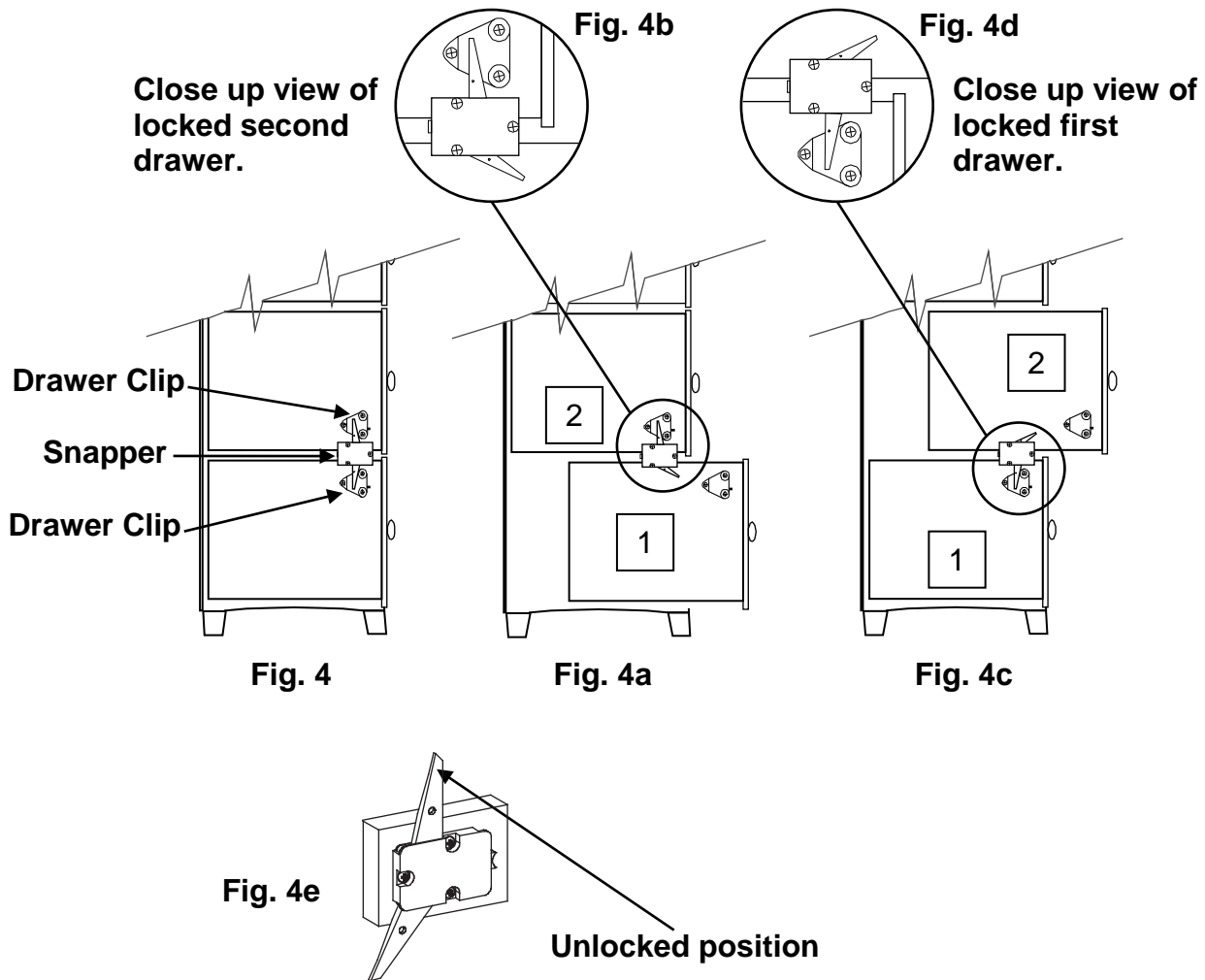

2403GACg 2403CAFg McKenzie Lateral File Cabinet

Assembly Instructions

5. Position the unit at your desired location. To level the unit, twist the Adjustable Glides (W) on the bottom two front corners. See Figure 5. Use a protective pad for the top surface.

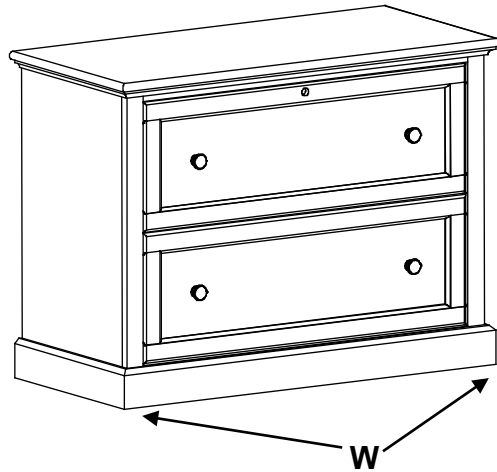

Fig. 5

There are two ways to help stabilize your file cabinet to reduce the risk of tip-over.

6. **Choice #1**
Remove the drawers from the cabinet. Place the cabinet against the wall. Using three #8 x 2-3/4" Black Screws (U), secure the unit to the wall. See Figure 6.

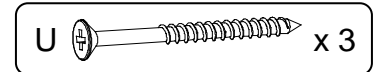
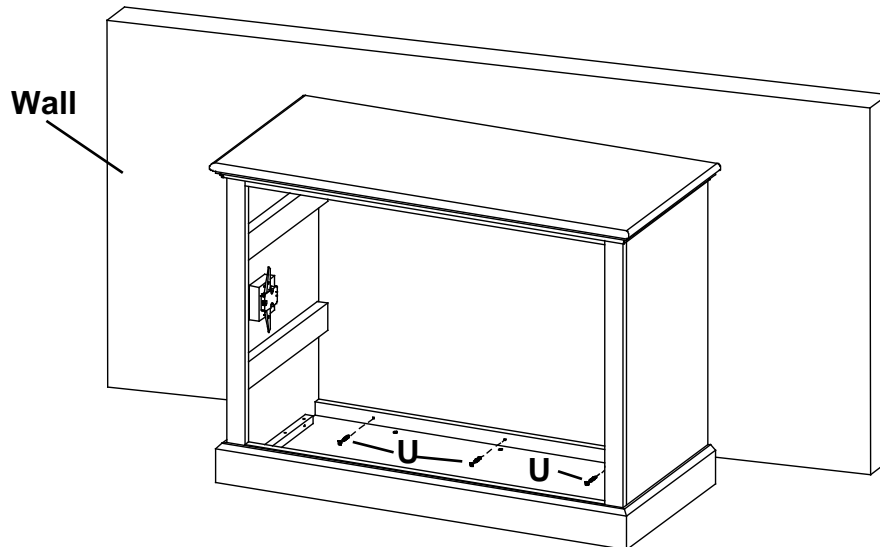

Fig. 6

2403GACg 2403CAFg McKenzie Lateral File Cabinet

Assembly Instructions

7. Choice #2

Using three #8 x 2-3/4" Black Screws (U), secure the file cabinet to the floor. See Figure 7.

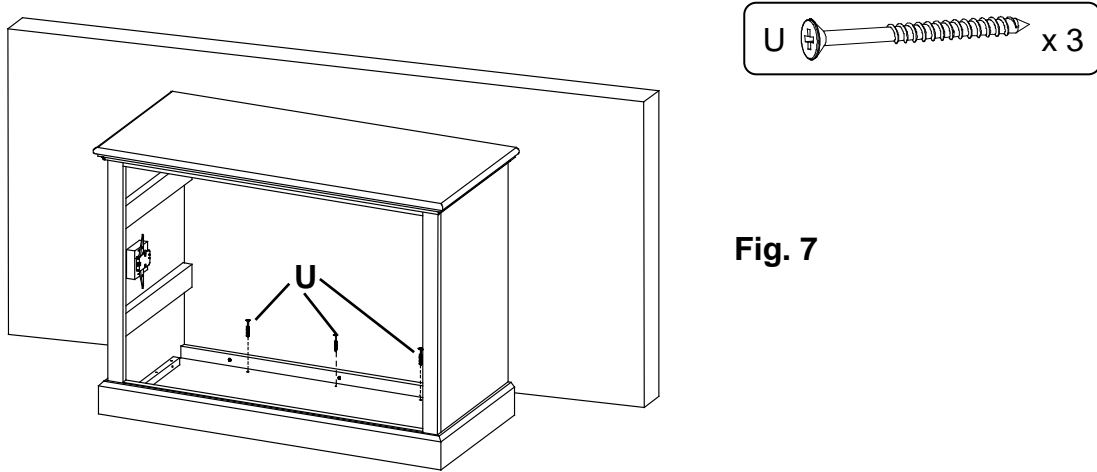

Fig. 7

8. The file drawers arrive configured to accommodate letter/letter sized files. But each drawer has the flexibility to be configured as letter/letter, letter/legal or legal/legal. To set up a section to hold legal files, remove a drawer. Remove one #8 x 1-5/8" Black Screw (S) from the drawer back and one from the bottom. Move the Drawer Divider (G) to the center slot. Attach the Divider in place with two #8 x 1-5/8" Black Screws (S). See Figures 8, 8a and 8b. Repeat for as many sections as you need.

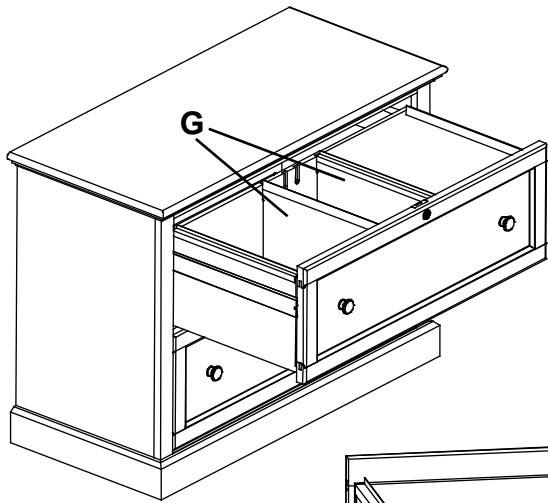

Fig. 8

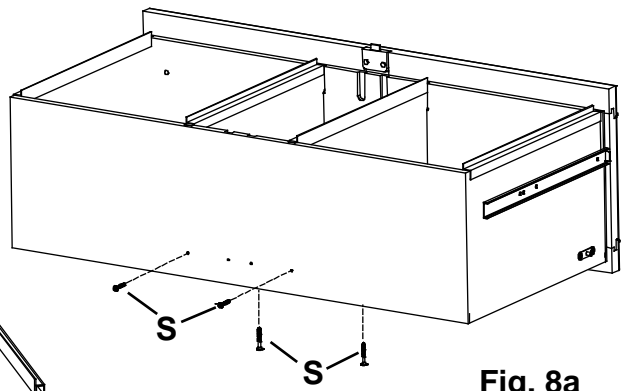

Fig. 8a

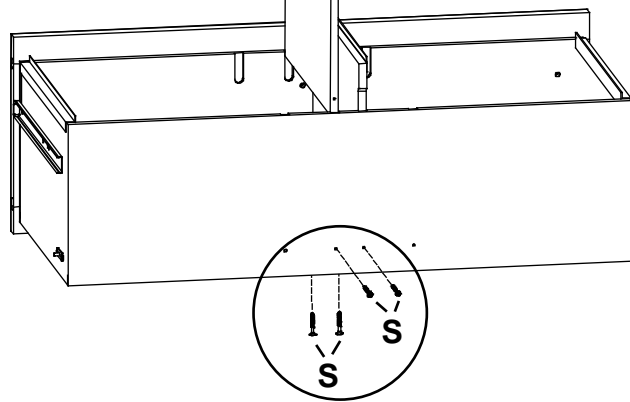

Fig. 8b