

ASSEMBLY INSTRUCTIONS

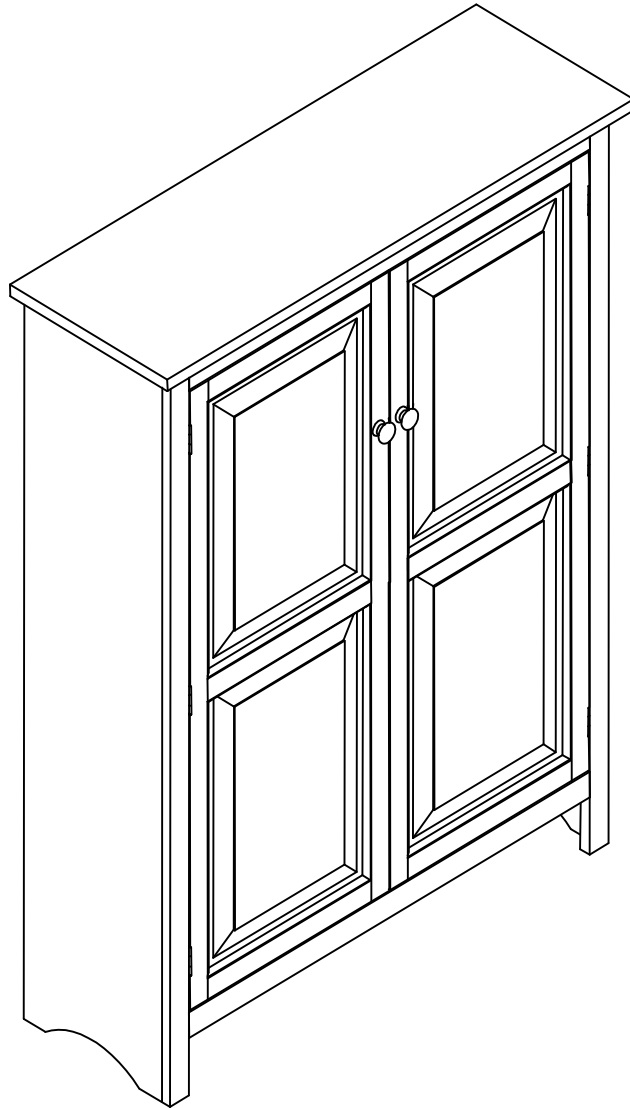

Description : DOUBLE JELLY CUPBOARD RTA
Item No. : CU-167

ITEM NO. : CU-167
REVISED MAR 24, 2016

Printed in Vietnam

BEFORE ASSEMBLY

Thank you for purchasing this quality product. This product has been designed for easy assembly and constructed for durability. All parts were checked prior to packaging to insure quality. Prior to beginning assembly, however, make sure all parts and hardware are included and free of obvious defect. If a part is missing or defective, please contact the store where purchased. If hardware is missing, or you need help with assembly, please call toll free 888-944-8396.

IMPORTANT NOTE:

- Place all wooden parts on a clean and smooth surface such as a rug or carpet to avoid the parts from being scratched.
- Remove all wrapping material, including staples & packing straps before you start to assemble.
- DO NOT tighten all screws and bolts until completely assembled.
- Keep all hardware parts out of reach of children.

WARNING:

Long exposure to rubber or soft plastic may cause a chemical reaction and damage the finish of your product. Protect the surface of the product with cloth if you are using any product with rubber feet or base.

ASSEMBLY TOOLS REQUIRED

NOT INCLUDED





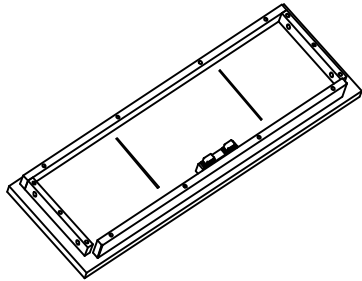
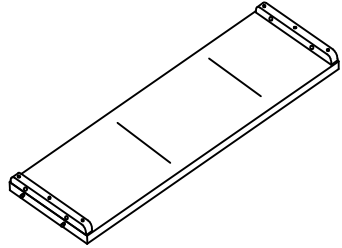
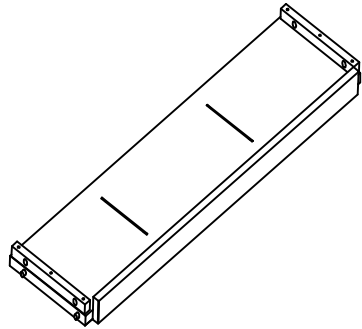
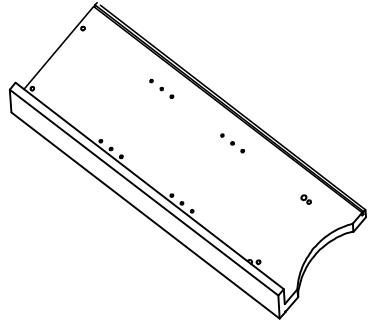
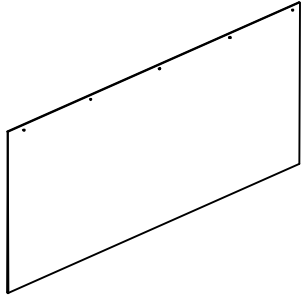
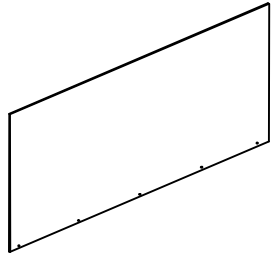
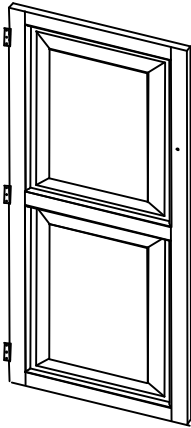
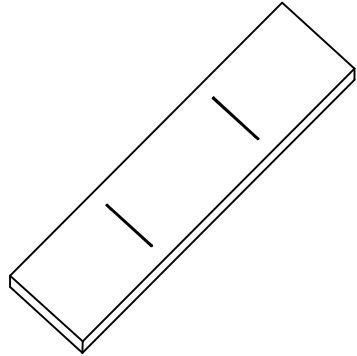

PART LIST

When unpacking, please be careful not to discard any parts with the packaging. Before continuing, please make sure you have the following parts:

NO	Description	Qty	Sketch	NO	Description	Qty	Sketch
A	Top	1		B	Shelf panel	1	
C	Bottom panel	1		D	Side panel (L-R)	2	
E	Upper Back panel (large)	1		F	Lower Back panel (small)	1	
G	Door (L-R)	2		H	Adjustable shelf	2	

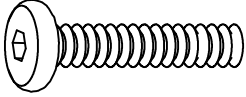
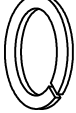
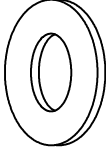
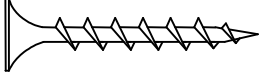
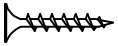
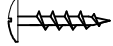
HARDWARE LIST

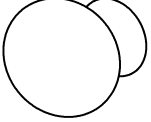
When unpacking, please be careful not to discard any parts with the packaging. Before continuing, please make sure you have all of the following hardware:

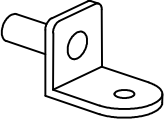
NO	Description	Qty	Sketch	NO	Description	Qty	Sketch
1	Bolt (M6 x 35mm)	12		2	Lock washer (φ6.5 x 11mm)	12	
3	Flat washer (φ6.5 x 19mm)	17		4	Long screw (M4 x 35mm)	1	
5	Short screw (M3.5 x 15mm)	28		6	Short pan head screw (M3.5 x 15mm)	15	
7	Allen key (M4 X 80mm)	1		8	Knob	2	
9	Long pan head screw (M4 x 28mm)	2		10	Steel band	1	
11	Shelf support bracket	8					

STEP 1

Attach side panels (D) to top (A), and shelves panel (B) and (C) with bolts (1), and washers (2) and (3) as shown below. Tighten with Allen key (7).

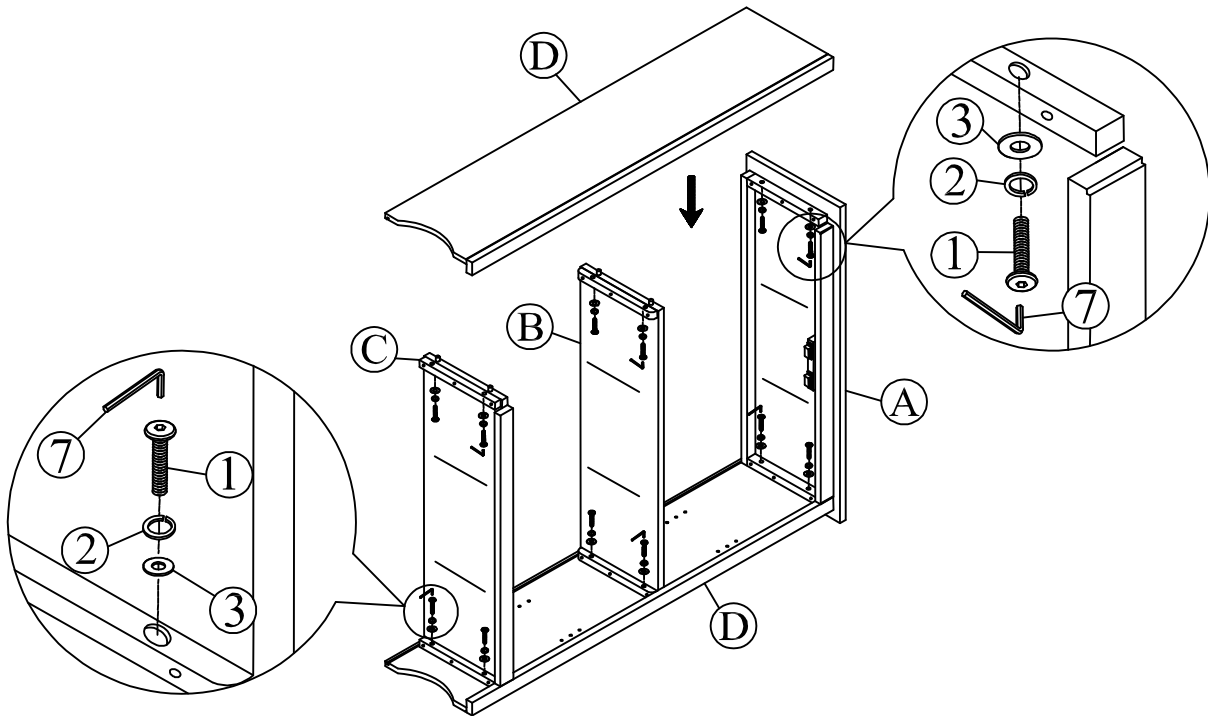

STEP 2

Slide back panels (E) and (F) into grooves of side panels (D), then attach back panel (E) to top (A) and back panel (F) to bottom panel (C) with pan head screws (6) as shown below. Tighten with a screwdriver.

Attach back panels (E) and (F) to shelf panel (B) with pan head screws (6) and washers (3) as shown below. Tighten with a screwdriver.

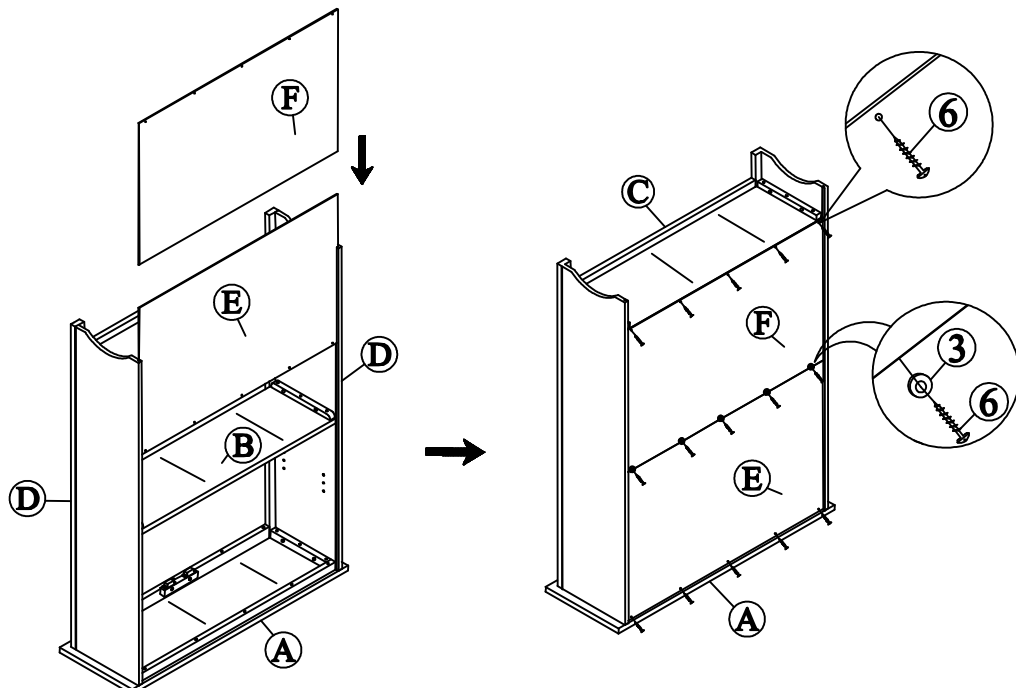

ITEM NO. : CU-167
REVISED MAR 24, 2016

Printed in Vietnam

STEP 3

Attach doors (G) to the unit with screws (5) as shown below. Tighten with a screwdriver.

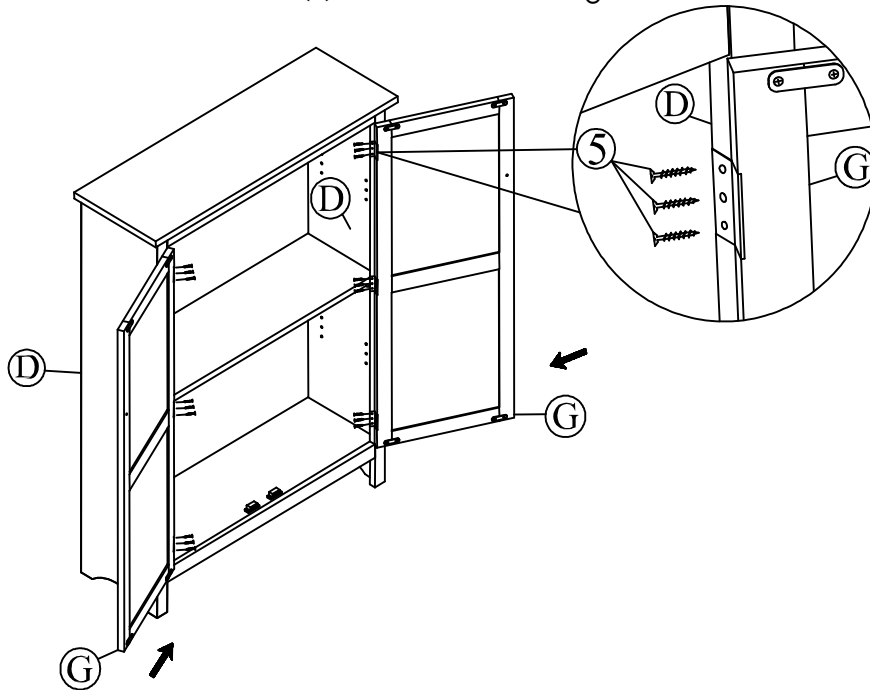

STEP 4

Attach knobs (8) to doors (G) with pan head screws (9) as shown below. Tighten with a screwdriver. Attach brackets (11) to side panels (D) as shown below. Then place the adjustable shelves (H) on the brackets and attach with screws (5). Tighten with a screwdriver.

Attach steel band (10) to the unit with screws (5) and attach steel band to the wall with screw (4) as shown below (to secure the product and prevent tipping). Tighten with a screwdriver.

