

ASSEMBLY INSTRUCTIONS

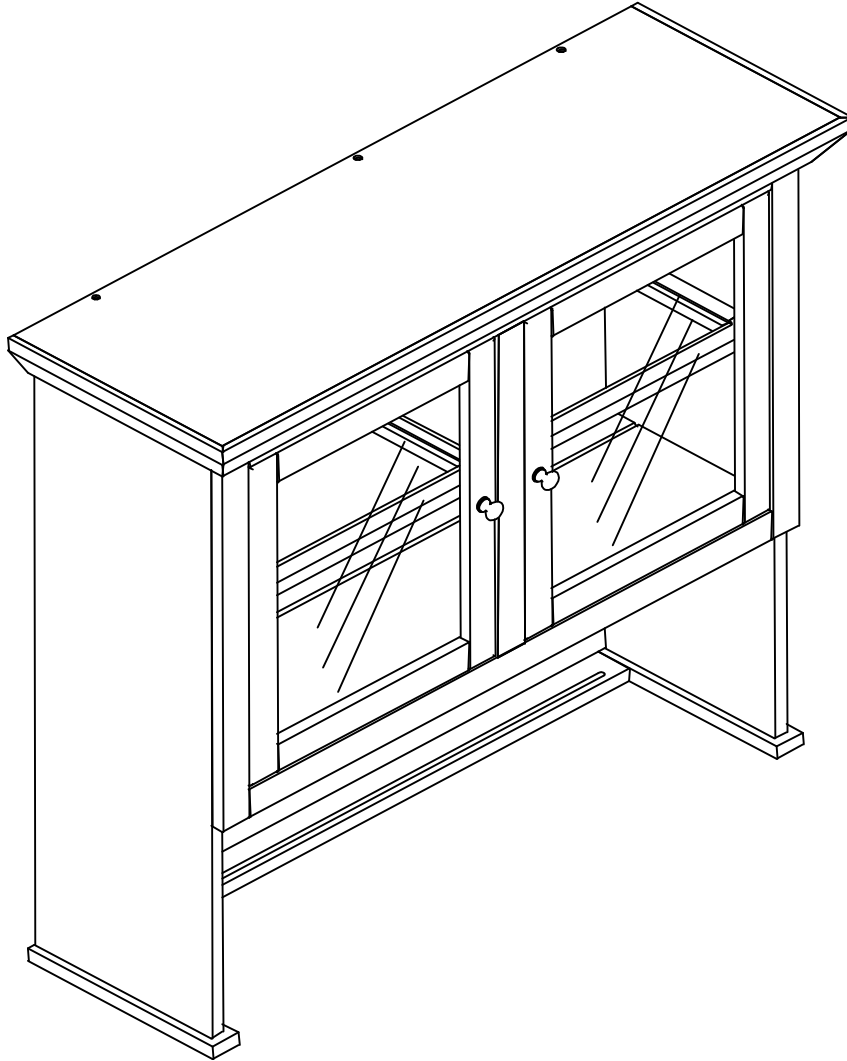

Description : HUTCH W/2 GLASS DOORS
Item No. : H-2

BEFORE ASSEMBLY

Thank you for purchasing this quality product. This product has been designed for easy assembly and constructed for durability. All parts were checked prior to packaging to insure quality. Prior to beginning assembly, however, make sure all parts and hardware are included and free of obvious defect. If a part is missing or defective, please contact the store where purchased. If hardware is missing, or you need help with assembly, please call toll free 888-944-8396.

IMPORTANT NOTE:

- Place all wooden parts on a clean and smooth surface such as a rug or carpet to avoid the parts from being scratched.
- Remove all wrapping material, including staples & packing straps before you start to assemble.
- DO NOT tighten all screws and bolts until completely assembled.
- Keep all hardware parts out of reach of children.

WARNING:

Long exposure to rubber or soft plastic may cause a chemical reaction and damage the finish of your product. Protect the surface of the product with cloth if you are using any product with rubber feet or base.





ASSEMBLY TOOLS REQUIRED

NOT INCLUDED



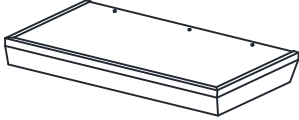

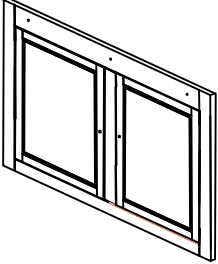
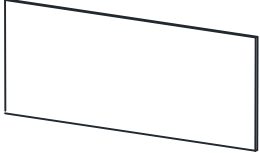
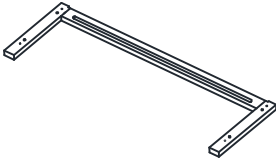
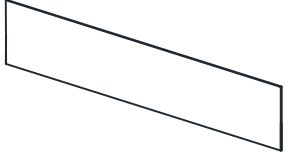
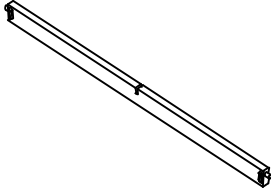
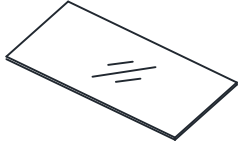

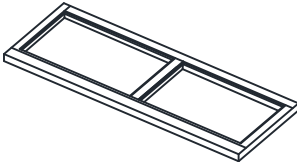
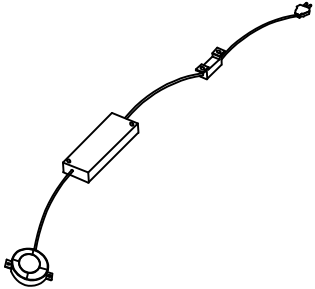



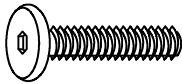

PART LIST

When unpacking, please be careful not to discard any parts with the packaging. Before continuing, please make sure you have the following parts:

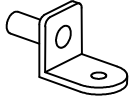
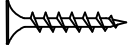
NO	Description	Qty	Sketch	NO	Description	Qty	Sketch
A	Crown	1		G	Bottom shelf	1	
B	Front frame with doors	1		H	Top back panel	1	
C	Base frame	1		I	Bottom back panel	1	
D	Back rail	1		J	Glass (Shelf)	2	
E	Side panel (L&R)	2		K	Glass (Door)	2	
F	Adjustable frame	1		L	Light (light-connector)	1	

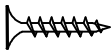
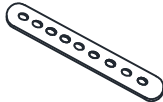
HARDWARE LIST

When unpacking, please be careful not to discard any parts with the packaging. Before continuing, please make sure you have all of the following hardware:

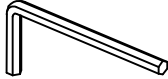
NO	Description	Qty	Sketch	NO	Description	Qty	Sketch
1	Bolt (M6 x 35mm)	4		8	Short Pan head Screw (M5 x 20mm)	6	
2	Lock Washer (φ6.5 x 11mm)	4		9	L-Bracket	2	
3	Flat Washer (φ6.5 x 13mm)	4		10	Bracket	4	
4	Long screw (M4 x 40mm)	2		11	Metal plate	1	
5	Medium screw (M4 x 30mm)	15		12	Steel band	1	
6	Short screw (M3.5 x 15mm)	16		13	Knob	2	
7	Long Pan head screw (M4 x 30mm)	2		14	Allen key (M4 X 80mm)	1	

STEP 1

Attach Light (L) to Crown (A) with screws (6). Tighten with a screwdriver.

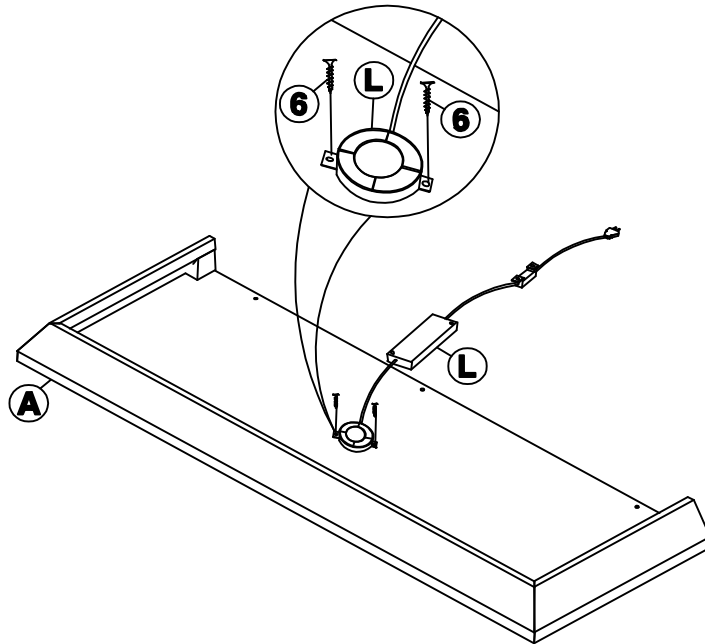

STEP 2

Attach glass sections (K) to back of front frame with doors (B), and lock it.
Attach knobs (13) to doors with pan head screws (7) as shown below. Tighten with a screwdriver.

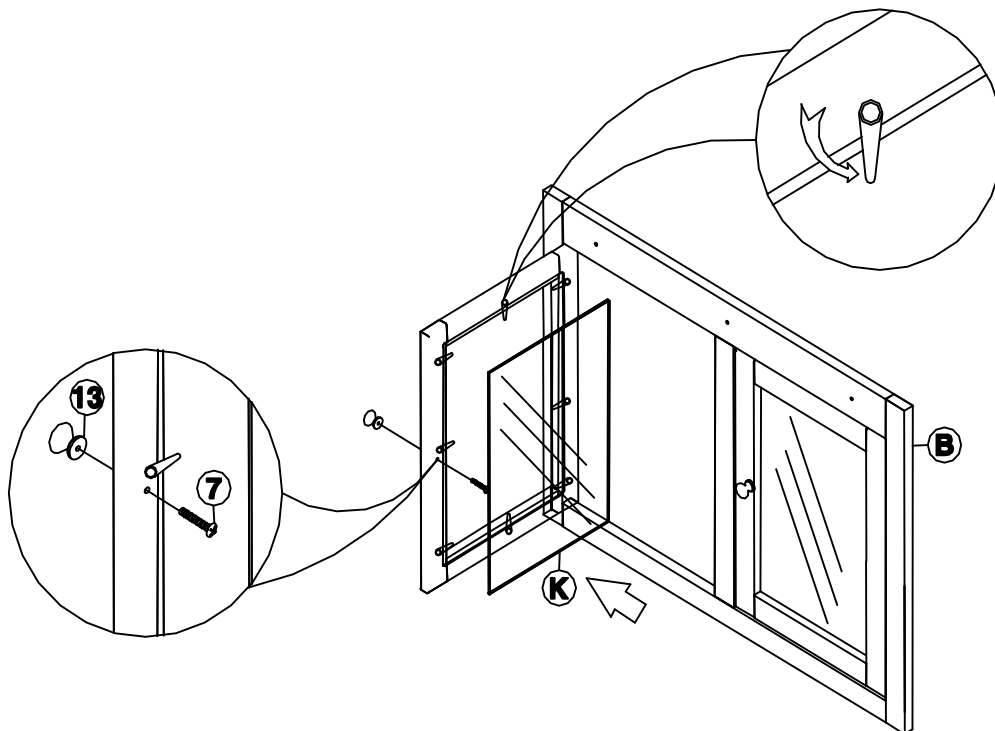

STEP 3

Attach back rail (D) to side panel (E) with pan head screw (8) as shown below. Tighten with a screwdriver.

Attach bottom shelf (G) to side panel (E) with bolts (1), and washers (2) and (3) as shown below. Tighten with Allen key (14).

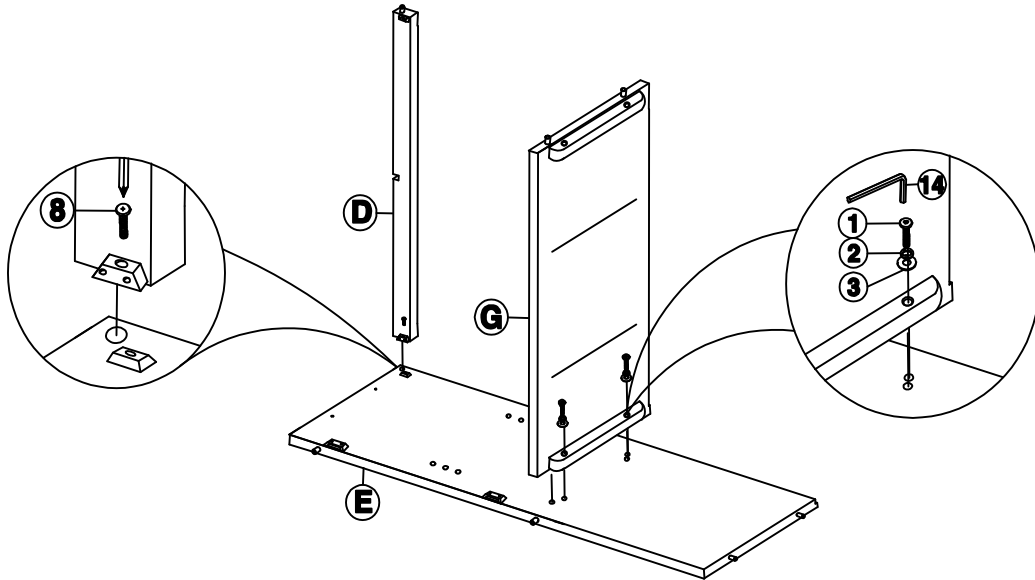

STEP 4

Slide top back panel (H) into groove as shown below.

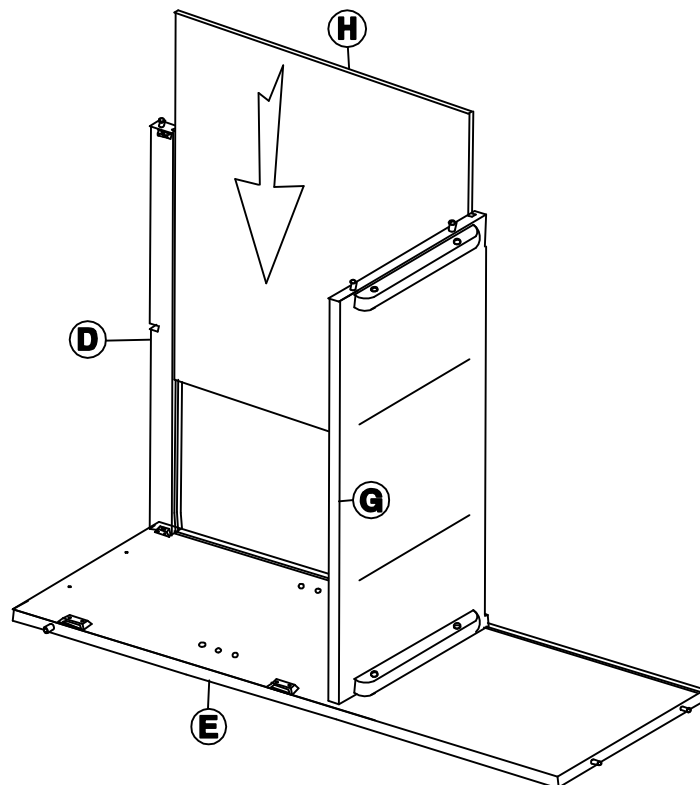

STEP 5

Attach back rail (D) to side panel (E) with pan head screw (8) as shown below. Tighten with a screwdriver.

Attach bottom shelf (G) to side panel (E) with bolts (1), and washers (2) and (3) as shown below. Tighten with Allen key (14).

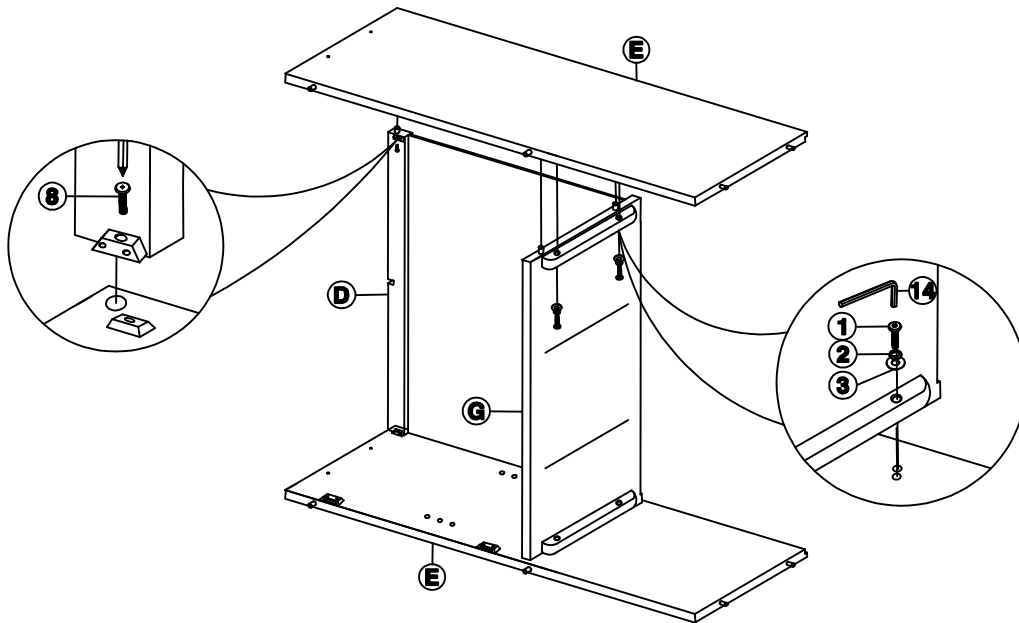

STEP 6

Attach front frame with doors (B) to unit with pan head screws (8) as shown below. Tighten with a screwdriver.

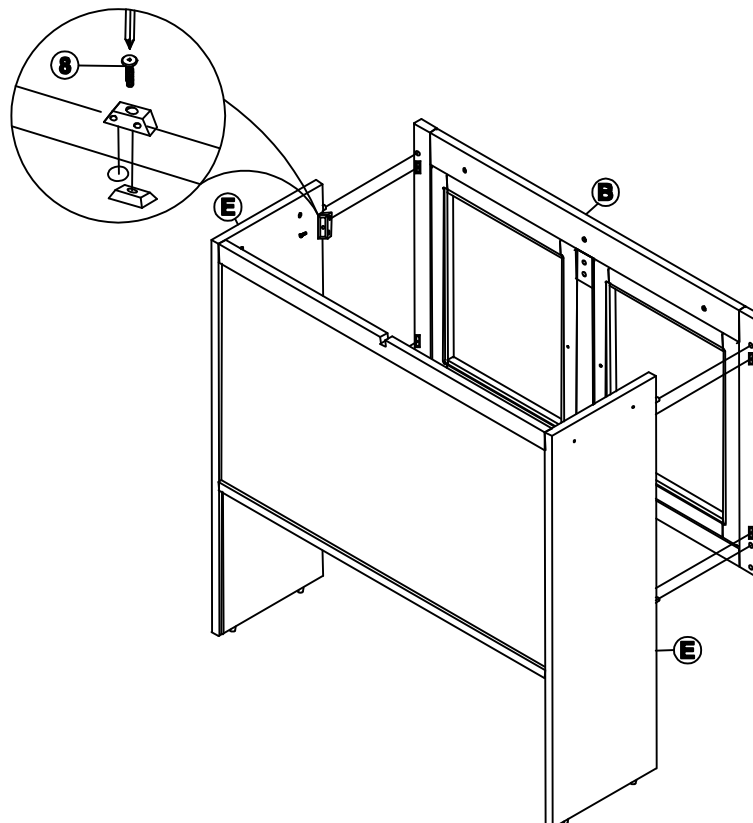

STEP 7

Attach L-brackets (9) with screws (6) as shown below. Tighten with a screwdriver.

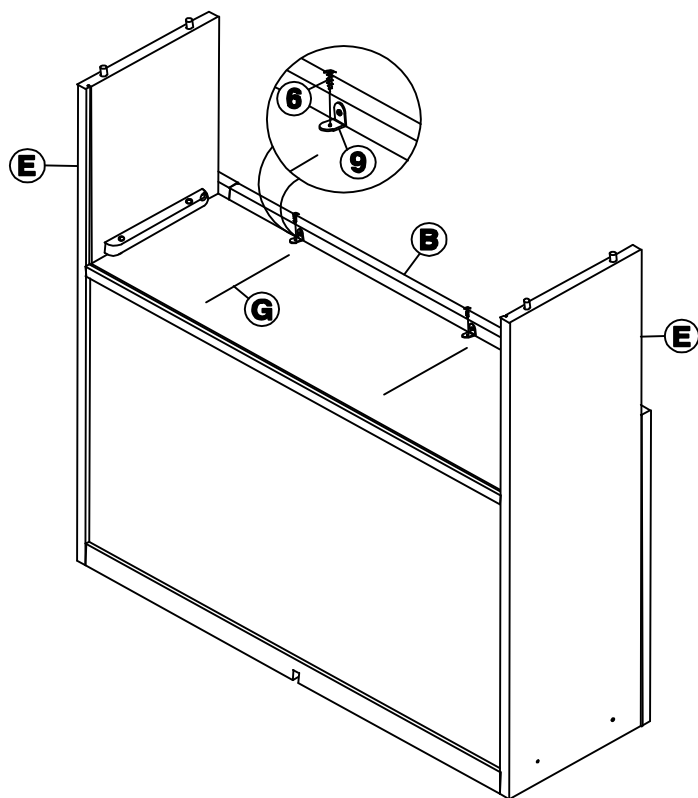

STEP 8

Slide bottom back panel (I) into groove as shown below.

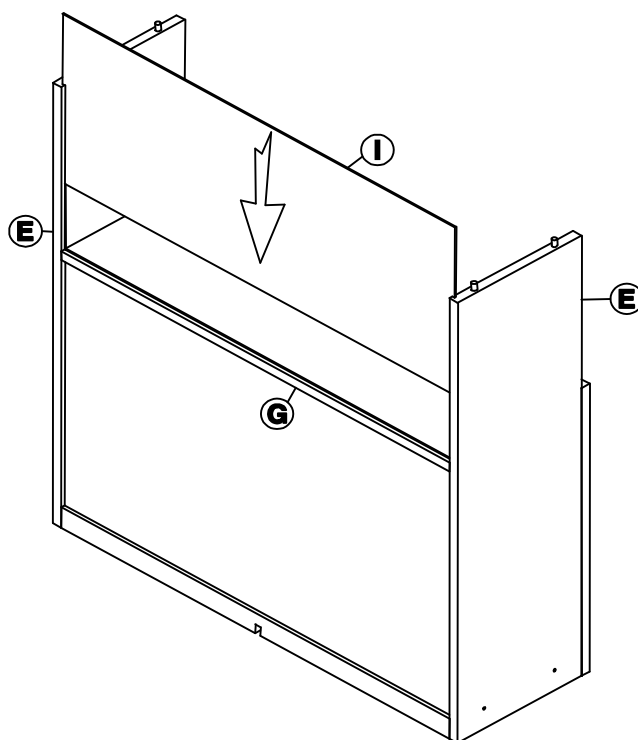

STEP 9

Attach base frame (C) to unit with screws (5) as shown below. Tighten with a screwdriver.

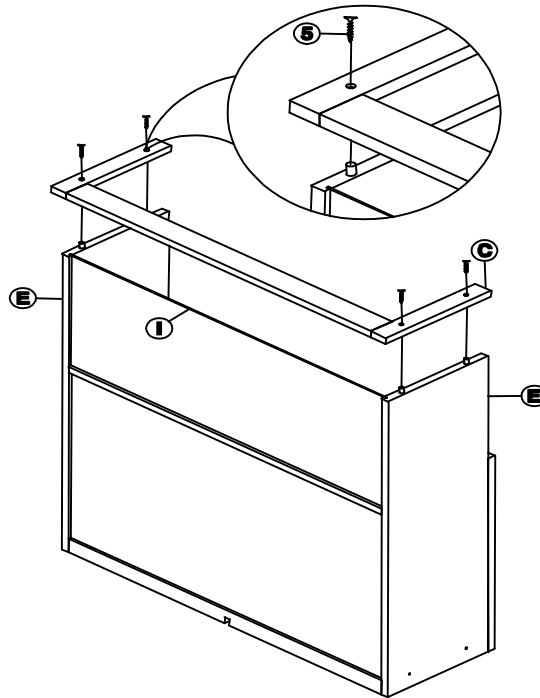

STEP 10

Insert brackets (10) into the unit. Place the frame (F) on the brackets and attach with screws (6). Tighten with a screwdriver.

Place glass shelves (J) on the frame (F) as shown below.

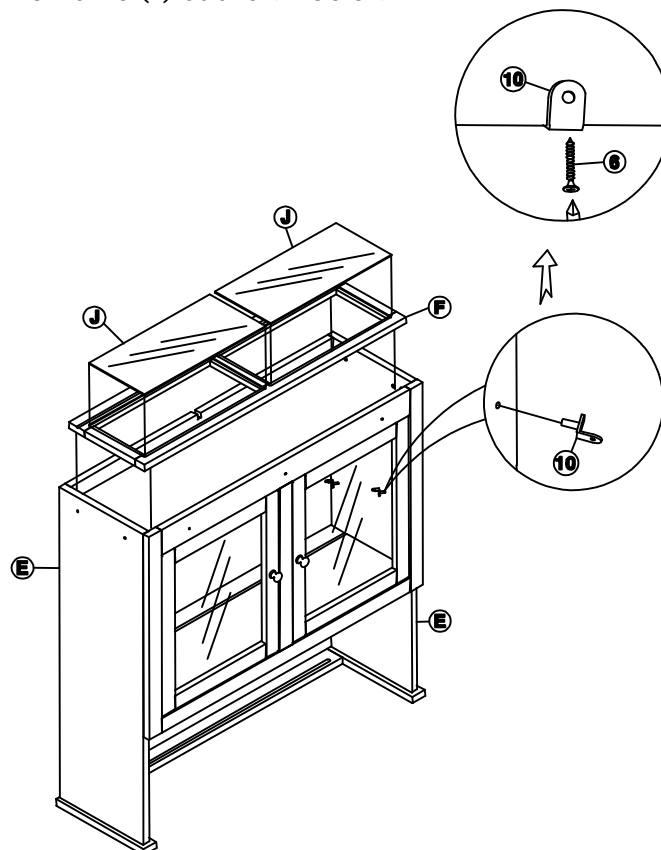

STEP 11

Attach crown (A) to the unit with screws (5) as shown below. Tighten with a screwdriver.

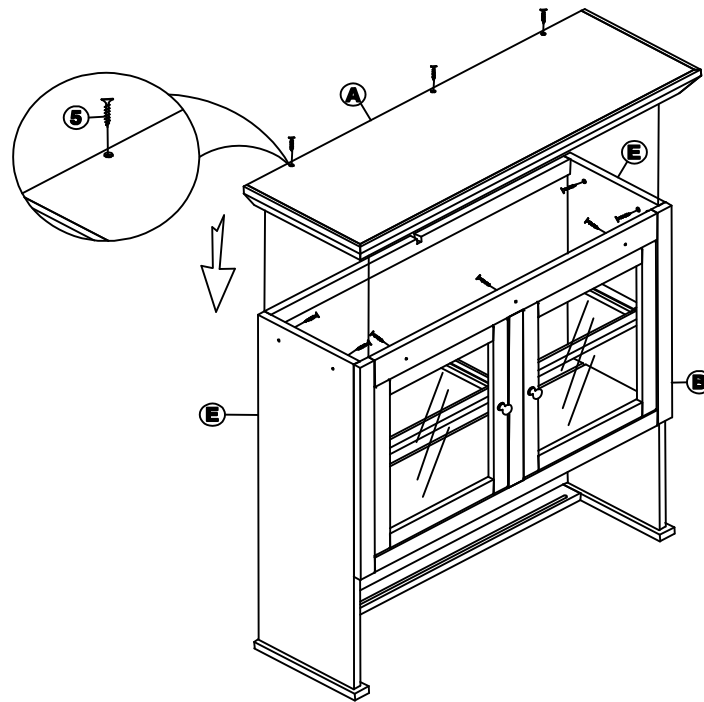

STEP 12

Attach connector (L) to the unit with screws (4), as shown below. Tighten with a screwdriver.

Attach metal plate (11) to unit with screws (6) as shown below. Attach metal plate (11) to Buffet or Server (to secure the product and prevent tipping). Tighten with a screwdriver.

Attach steel band (12) to unit with screws (6) and attach steel band (12) to the wall with screw (5) as shown below (to secure the product and prevent tipping). Tighten with a screwdriver.

