

ASSEMBLY INSTRUCTIONS

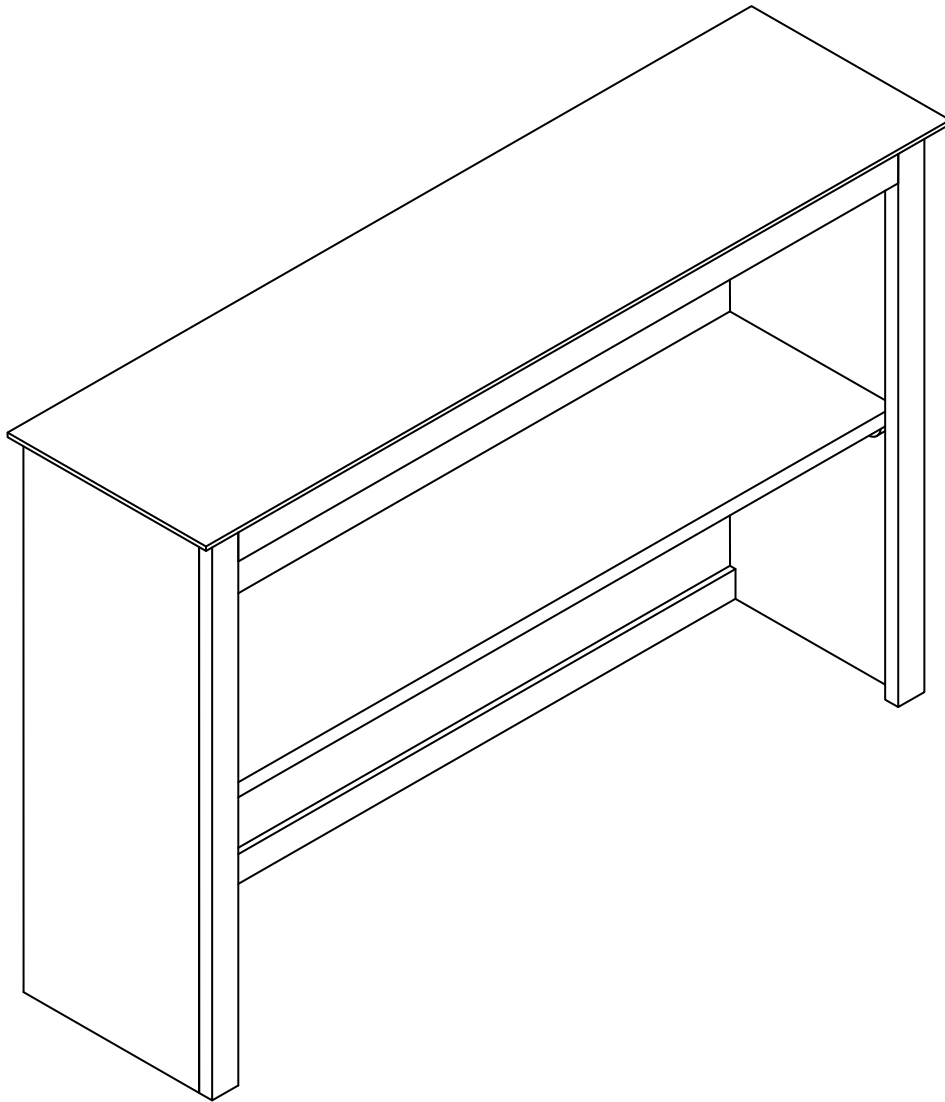

Description : DESK HUTCH 45X12X30H
Item No. : OF-65H

ITEM NO.: OF-65H
ISSUED MAY 17, 2017

Printed in Vietnam

BEFORE ASSEMBLY

Thank you for purchasing this quality product. This product has been designed for easy assembly and constructed for durability. Please take the time to read and follow the assembly instructions carefully.

Be sure to check all packing material carefully for small parts which may have come loose inside the carton during shipment. Please separate, identify, and count all parts and metal hardware. Compare with part list to be sure all parts are present. If hardware is missing or you have difficulty assembling this product, please call Toll Free: 1-888-944-8396.

IMPORTANT NOTE:

- Place all wooden parts on a clean and smooth surface such as a rug or carpet to avoid the parts from being scratched.
- Remove all wrapping material, including staples & packing straps before you start to assemble.
- DO NOT tighten all screws and bolts until completely assembled.
- Keep all hardware parts out of reach of children.

WARNING:

Long exposure to rubber or soft plastic may cause a chemical reaction and damage the finish of your table. Protect the surface of the table with cloth if you are using any product with rubber feet or base.

ASSEMBLY TOOLS REQUIRED

NOT INCLUDED



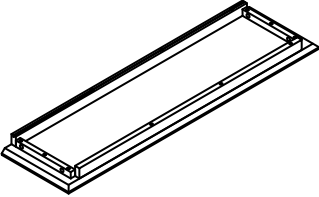
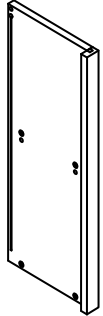
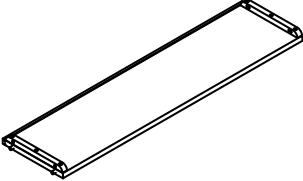
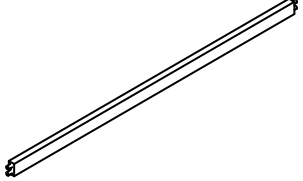
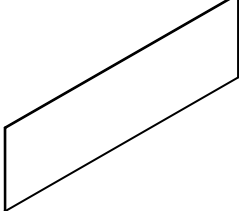

PART LIST

When unpacking, please be careful not to discard any parts with the packaging. Before continuing, please make sure you have the following parts:

NO	Description	Qty	Sketch	NO	Description	Qty	Sketch
A	Top	1		B	Side panel	2	
C	Shelf	1		D	Crossbar	1	
E	Back panel	2					

HARDWARE LIST

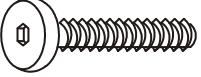
When unpacking, please be careful not to discard any parts with the packaging. Before continuing, please make sure you have all of the following hardware:

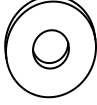
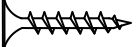
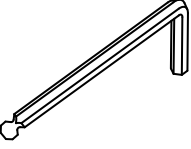
NO	Description	Qty	Sketch	NO	Description	Qty	Sketch
1	Bolt (M6 x 30mm)	8		2	Lock washer (Ø6.5 x 11mm)	8	
3	Flat Washer (Ø6.5 x 13mm)	8		4	Screw (M4 x 35mm)	2	
5	Allen Key (M4 x 30mm x 110mm)	1					

ITEM NO.: OF-65H
ISSUED MAY 17, 2017

Printed in Vietnam

STEP 1

Attach the top (A) and shelf (C) to side panel (B) with bolts (1), and washers (2) and (3) as shown below. Tighten with Allen key (5).

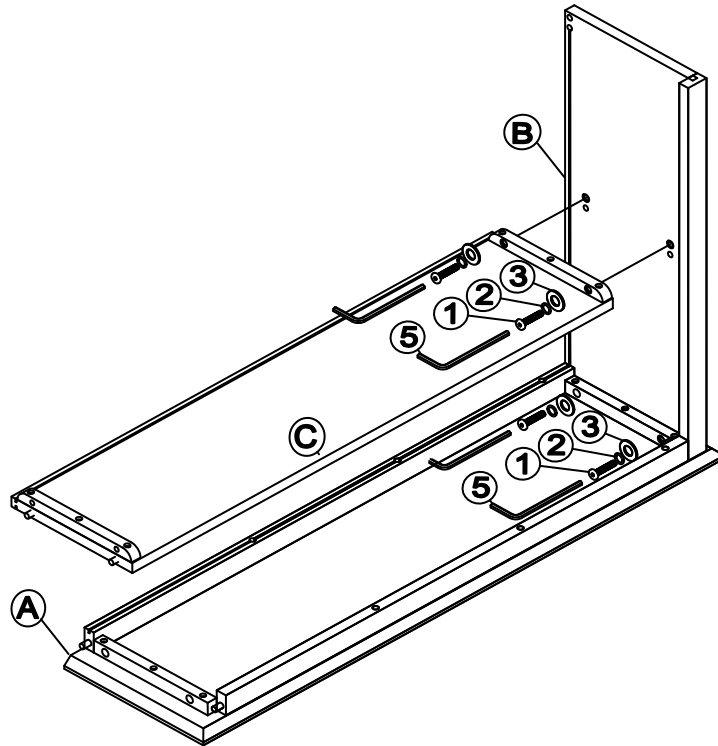

STEP 2

Attach the crossbar (D) to side panel (B) with screw (4) as shown below. Tighten with a screwdriver.

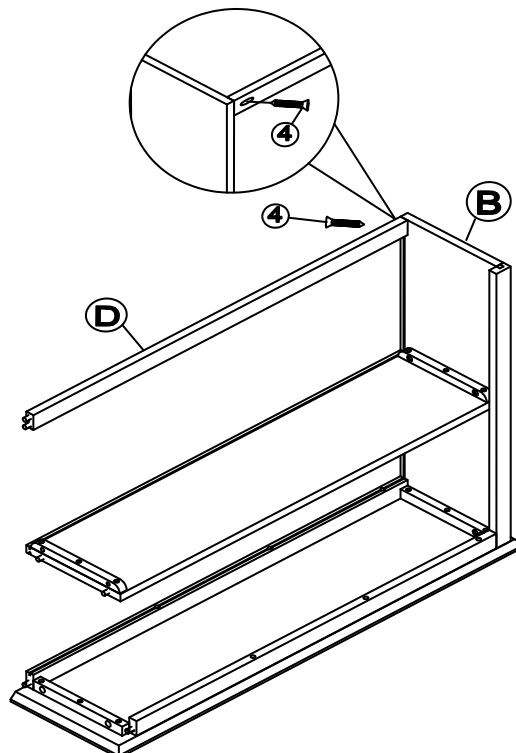

STEP 3

Slide back panels (E) into the grooves as shown below.

Attach crossbar (D) to the other side panel (B) with screw (4) as shown below. Tighten with a screwdriver. Attach top (A) and shelf (C) to the other side panel (B) with bolts (1), and washers (2) and (3) as shown below. Tighten with Allen key (5).

