

ASSEMBLY INSTRUCTIONS

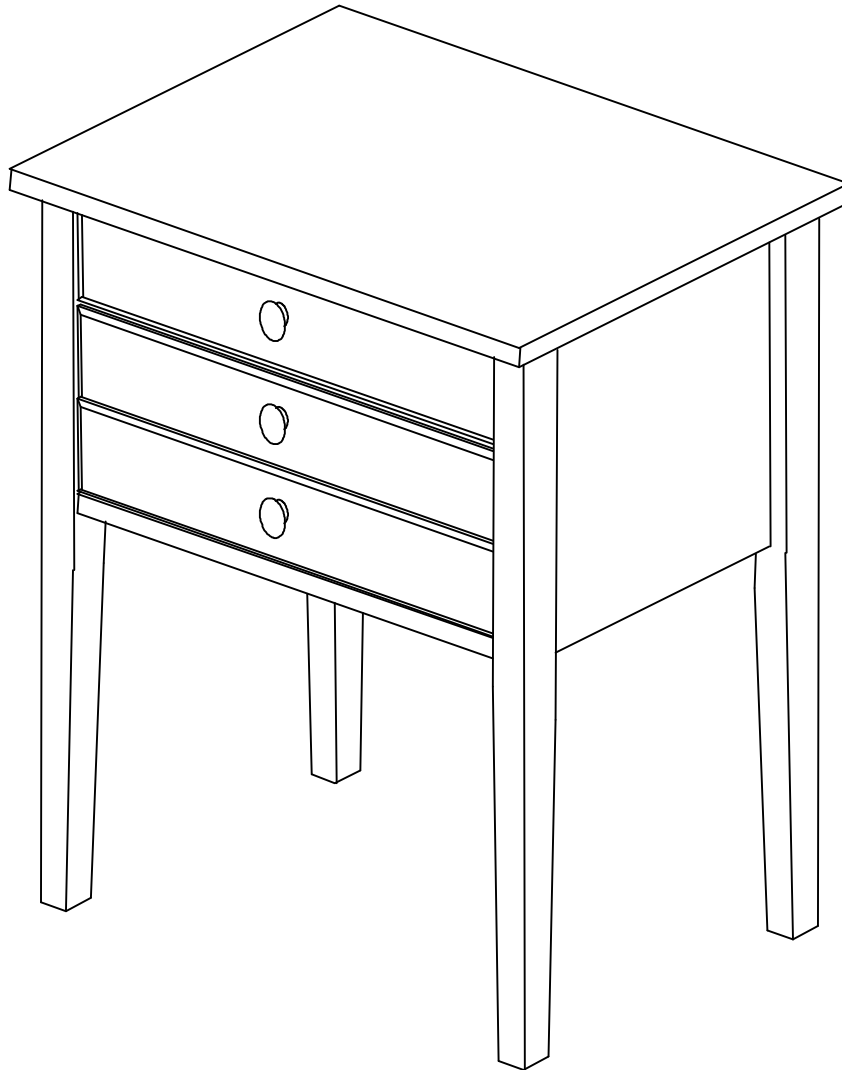

Description : 2 DRAWER COUNTRY ACCENT TABLE
Item No. : OT-66

BEFORE ASSEMBLY

Thank you for purchasing this quality product. This product has been designed for easy assembly and constructed for durability. All parts were checked prior to packaging to insure quality. Prior to beginning assembly, however, make sure all parts and hardware are included and free of obvious defect. If a part is missing or defective, please contact the store where purchased. If hardware is missing, or you need help with assembly, please call toll free 888-944-8396.

IMPORTANT NOTE:

- Place all wooden parts on a clean and smooth surface such as a rug or carpet to avoid the parts from being scratched.
- Remove all wrapping material, including staples & packing straps before you start to assemble.
- DO NOT tighten all screws and bolts until completely assembled.
- Keep all hardware parts out of reach of children.

WARNING:

Long exposure to rubber or soft plastic may cause a chemical reaction and damage the finish of your table. Protect the surface of the table with cloth if you are using any product with rubber feet or base.



ASSEMBLY TOOLS REQUIRED

NOT INCLUDED





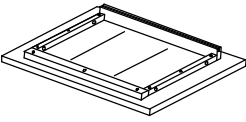

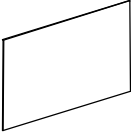
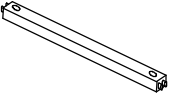
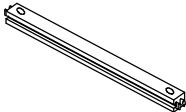
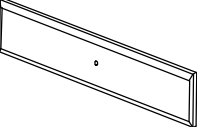
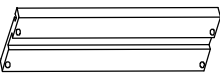
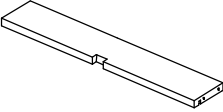
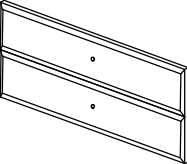
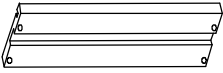
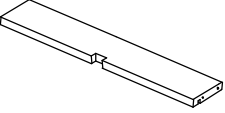
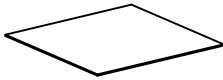
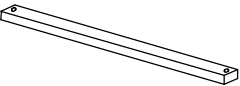
PART LIST

When unpacking, please be careful not to discard any parts with the packaging. Before continuing, please make sure you have the following parts.

NO	Description	Qty	Sketch	NO	Description	Qty	Sketch
A	Top	1		B	Side panel (L - R)	2	
C	Back panel	1		D	Front apron	1	
E	Back apron	1		F	Upper Drawer front	1	
G	Upper Drawer side	2		H	Upper Drawer back	1	
I	Lower Drawer front	1		J	Lower Drawer side	2	
K	Lower Drawer back	1		L	Drawer bottom	2	
M	Rail	2					

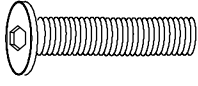
HARDWARE LIST

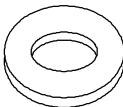
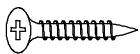
When unpacking, please be careful not to discard any parts with the packaging. Before continuing, please make sure you have all of the following hardware:

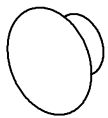
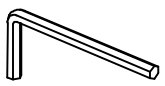
NO	Description	Qty	Sketch	NO	Description	Qty	Sketch
1	Bolt (M6 x 35mm)	4		2	Lock Washer (Φ6.5 x 11mm)	4	
3	Flat Washer (Φ6.5 x 19mm)	4		4	Screw (M4x30mm)	24	
5	Pan head screw (M4 x 25 mm)	3		6	Knob (Φ38x30mm)	3	
7	Allen key (K4x80mm)	1					

STEP 1

Attach side panel (B) to top (A) with bolts (1), and washers (2) and (3) as shown below. Tighten with Allen key (7).

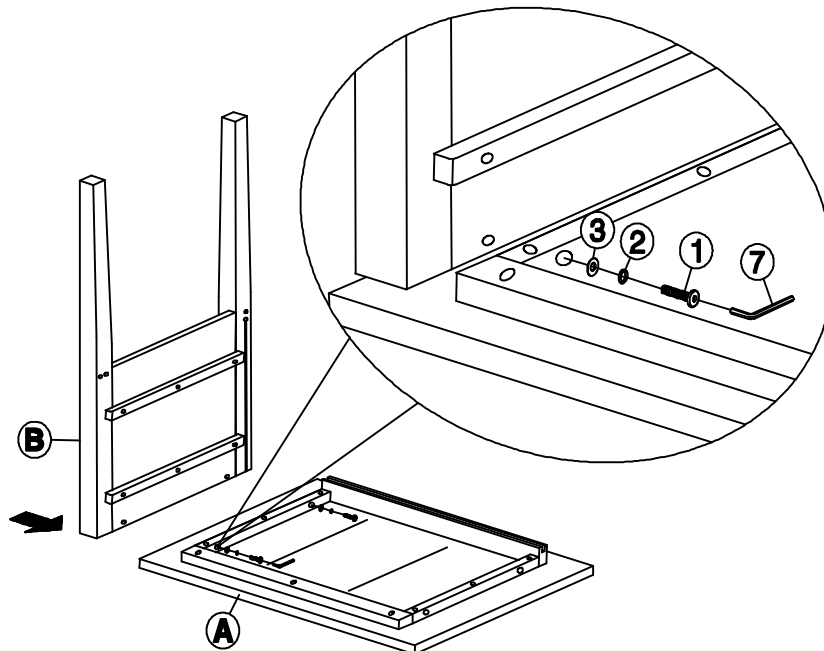

STEP 2

Slide back panel (C) into the grooves as shown below.

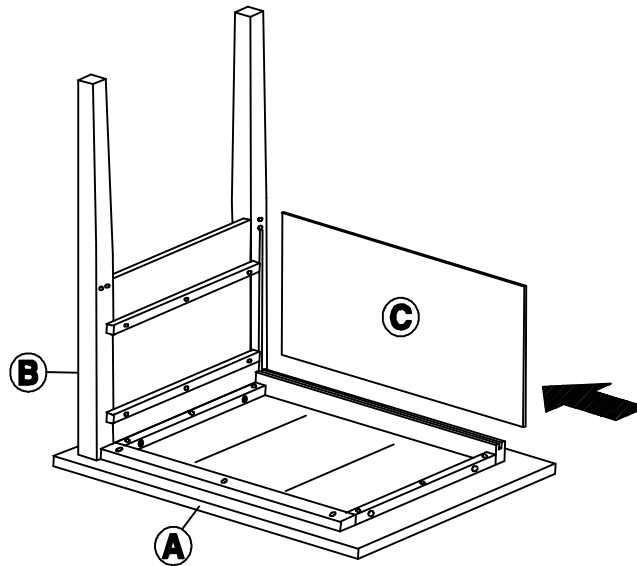

STEP 3

Attach front apron (D) and back apron (E) to the side panel (B) with screws (4) as shown below. Tighten with a screwdriver.

Attach side panel (B) to top (A) with bolts (1), and washers (2) and (3) as shown below. Tighten with Allen key (7).

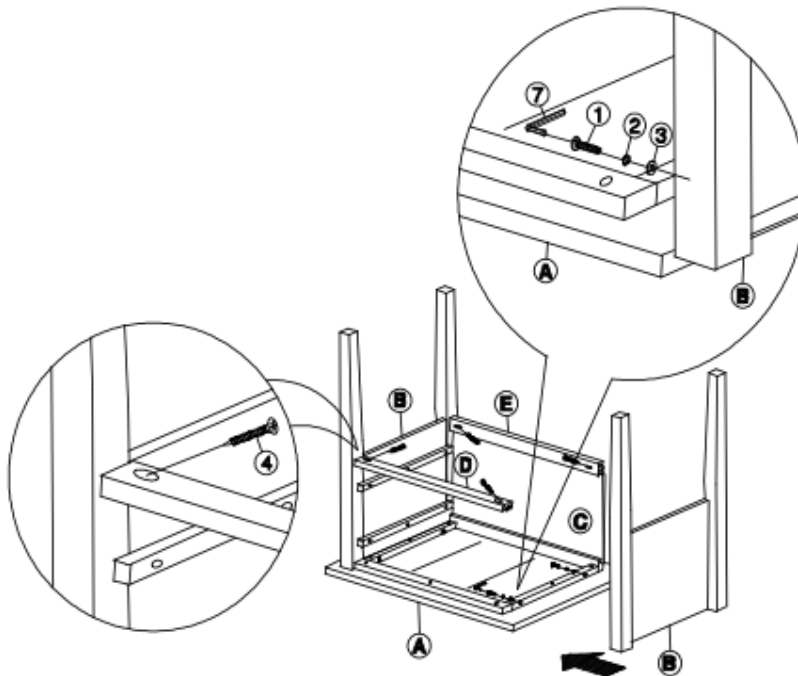

STEP 4

Attach drawer side (G) to drawer front (F) and drawer back (H) with screws (4). Tighten with a screwdriver.

Slide drawer bottom (L) into the grooves as shown below.

Then attach drawer side (G) to the unit with screws (4) as shown below. Tighten with a screwdriver.
Attach rail (M) to drawer front (F) and drawer back (H) with screws (4). Tighten with a screwdriver.

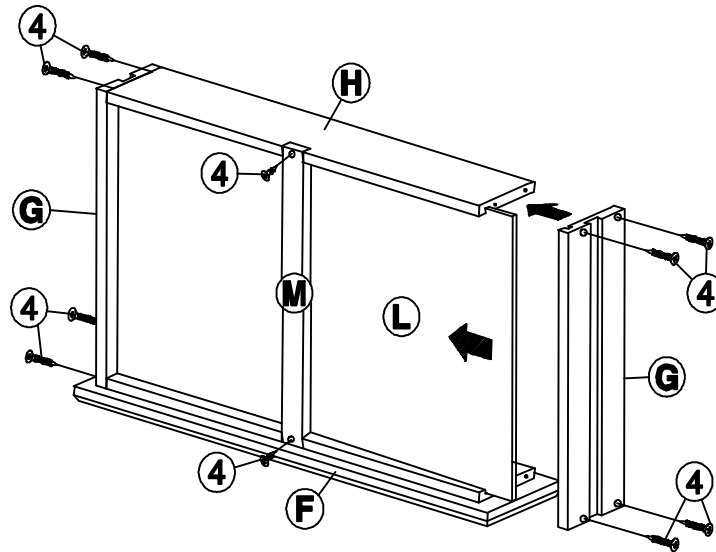

STEP 5

Attach drawer side (J) to drawer front (I) and drawer back (K) with screws (4). Tighten with a screwdriver.

Slide drawer bottom (L) into the grooves as shown below.

Then attach drawer side (J) to the unit with screws (4) as shown below. Tighten with a screwdriver.
Attach rail (M) to drawer front (I) and drawer back (K) with screws (4). Tighten with a screwdriver.

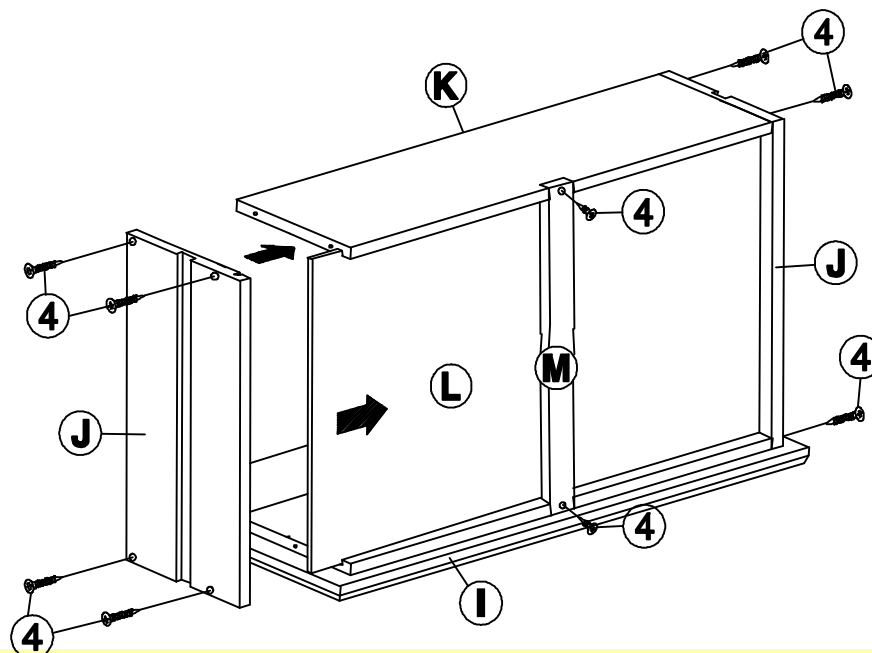

STEP 6

Put drawers into the unit as shown below.

Attach knobs (6) to front of drawer with pan head screws (5). Tighten with a screwdriver.

