

ASSEMBLY INSTRUCTIONS



Description : KITCHEN WORKCENTER
Item No. : WC-3222

BEFORE ASSEMBLY

Thank you for purchasing this quality product. This product has been designed for easy assembly and constructed for durability. All parts were checked prior to packaging to insure quality. Prior to beginning assembly, however, make sure all parts and hardware are included and free of obvious defect. If a part is missing or defective, please contact the store where purchased. If hardware is missing, or you need help with assembly, please call toll free 888-944-8396.

IMPORTANT NOTE:

- Place all wooden parts on a clean and smooth surface such as a rug or carpet to avoid the parts from being scratched.
- Remove all wrapping material, including staples & packing straps before you start to assemble.
- DO NOT tighten all screws and bolts until completely assembled.
- Keep all hardware parts out of reach of children.



WARNING:

Long exposure to rubber or soft plastic may cause a chemical reaction and damage the finish of your product. Protect the surface of the product with cloth if you are using any product with rubber feet or base.

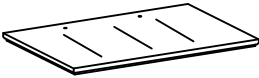
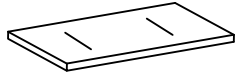
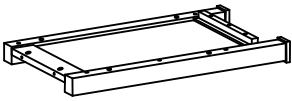
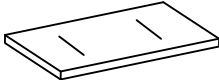
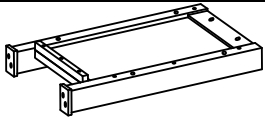
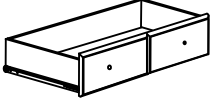
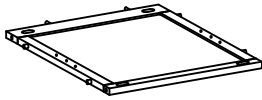
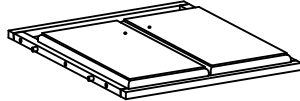

PART LIST

When unpacking, please be careful not to discard any parts with the packaging. Before continuing, please make sure you have the following parts:









NO	Description	Qty	Sketch	NO	Description	Qty	Sketch
A	Top Panel	1		F	Bottom shelf	1	
B	Left side panel	1		G	Adjustable shelf	1	
C	Right side panel	1		H	Assembled drawer	1	
D	Back panel	1		I	Front panel with door	1	
E	Top rail	2					

ITEM NO.: WC-3222
REVISED JAN 03, 2015

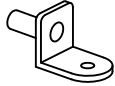
Printed in Vietnam

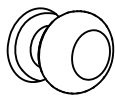
HARDWARE LIST

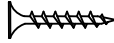
When unpacking, please be careful not to discard any parts with the packaging. Before continuing, please make sure you have all of the following hardware:

NO	Description	Qty	Sketch	NO	Description	Qty	Sketch
1	Long bolt (M6x45mm)	10		2	Pan head screw (M4x30mm)	4	
3	Shelf support bracket	4		4	Long wood screw (M4x38mm)	9	
5	Wooden knob	4		6	U - washer	4	
7	Short wood screw (M3x15mm)	4		8	Allen key (4x80mm)	1	

STEP 1

Attach Left side panel (B) to back panel (D) with Long bolts (1), and U-washers (6). Tighten with Allen key (8).

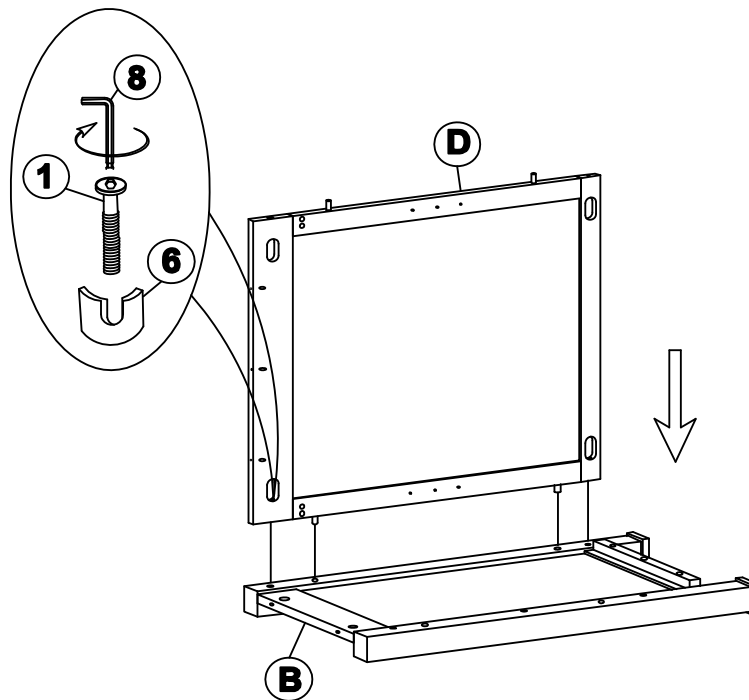

STEP 2

Attach Right side panel (C) to back panel (D) with Long bolts (1), and U-washers (6). Tighten with Allen key (8).

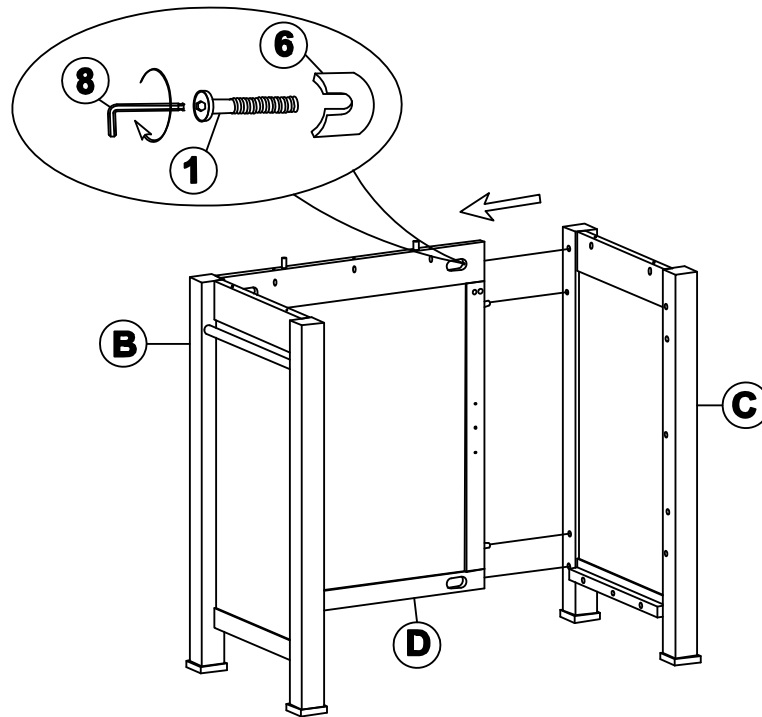

STEP 3

Insert Top rails (E) into the unit as shown below.

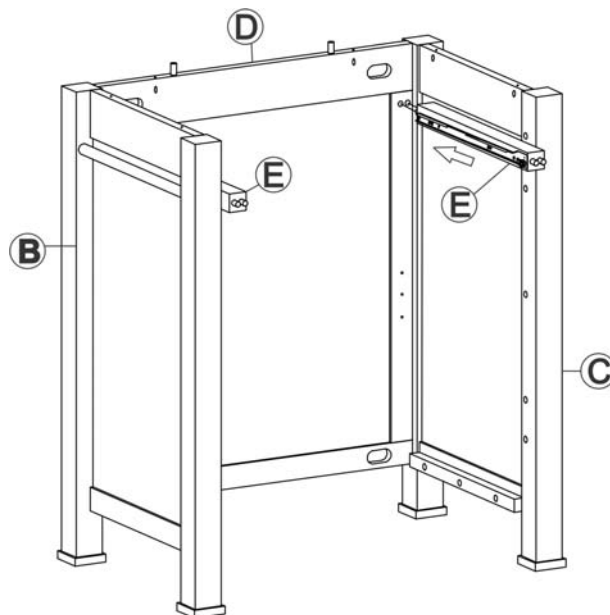

STEP 4

Attach knobs (5) to front panel with door (1) with screws (2) .Tighten with a screwdriver.

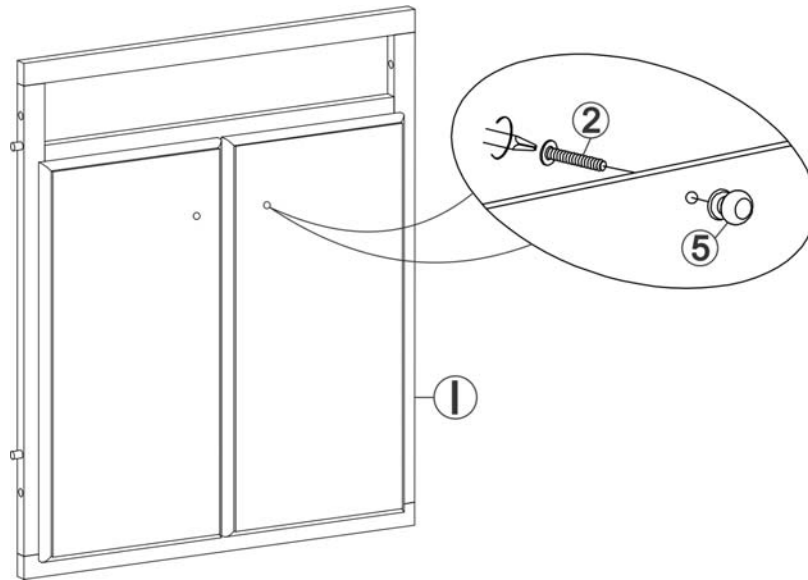

STEP 5

Attach Front panel with door (1) to the unit with bolts (1) as shown below .Tighten with Allen key (8).

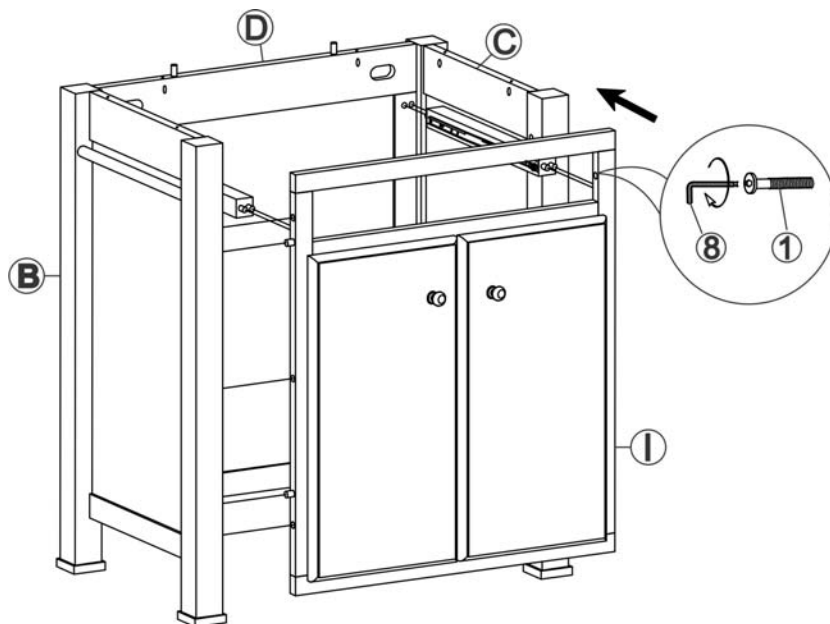

STEP 6

Attach Top (A) to the unit with screws (4). Tighten with a screwdriver.

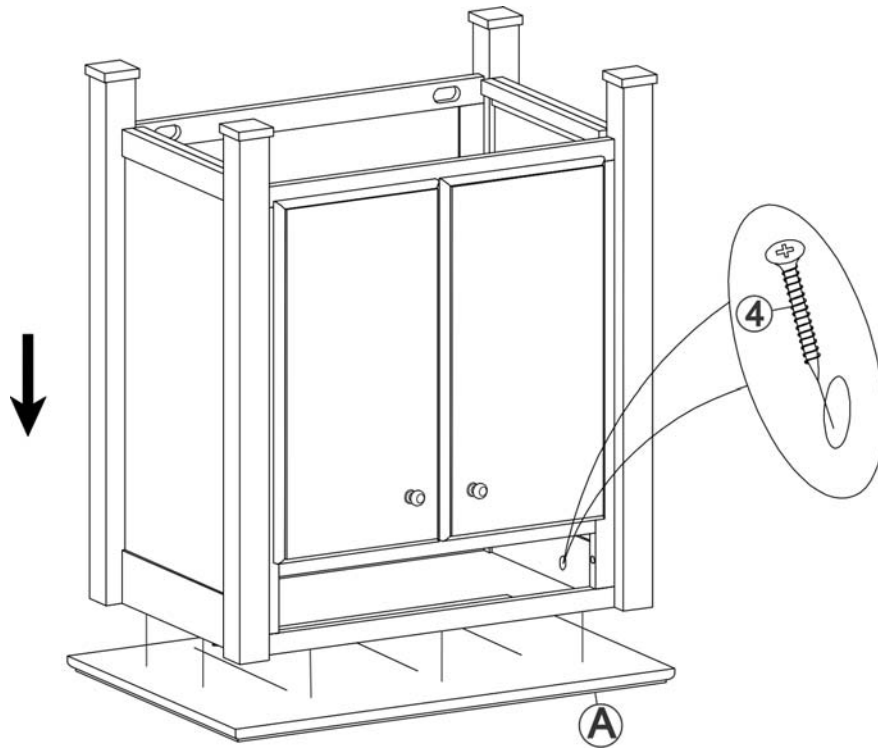

STEP 7

Attach knobs (5) to front of drawers (H) with screws (2). Tighten with a screwdriver.

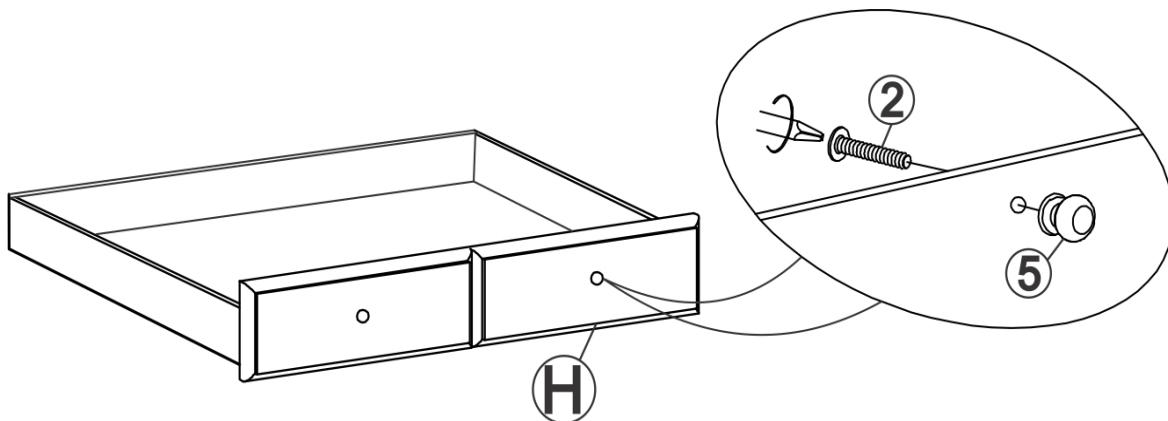

STEP 8

Insert the drawer (H) into the unit as shown below.

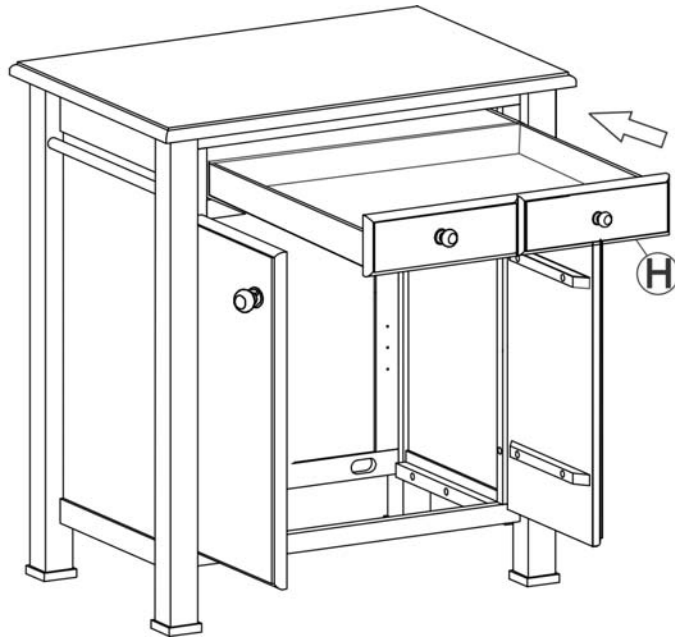

STEP 9

Place Bottom shelf (F) into the unit as shown below.

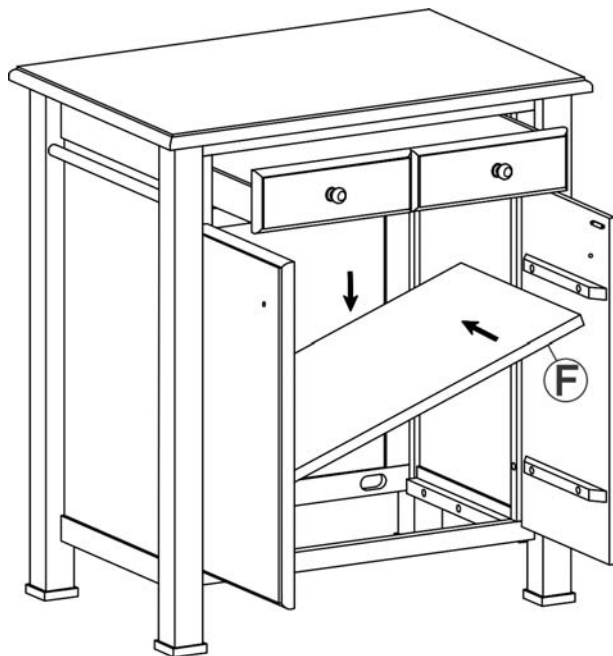

STEP 10

Insert the brackets (3) to the unit as shown below.

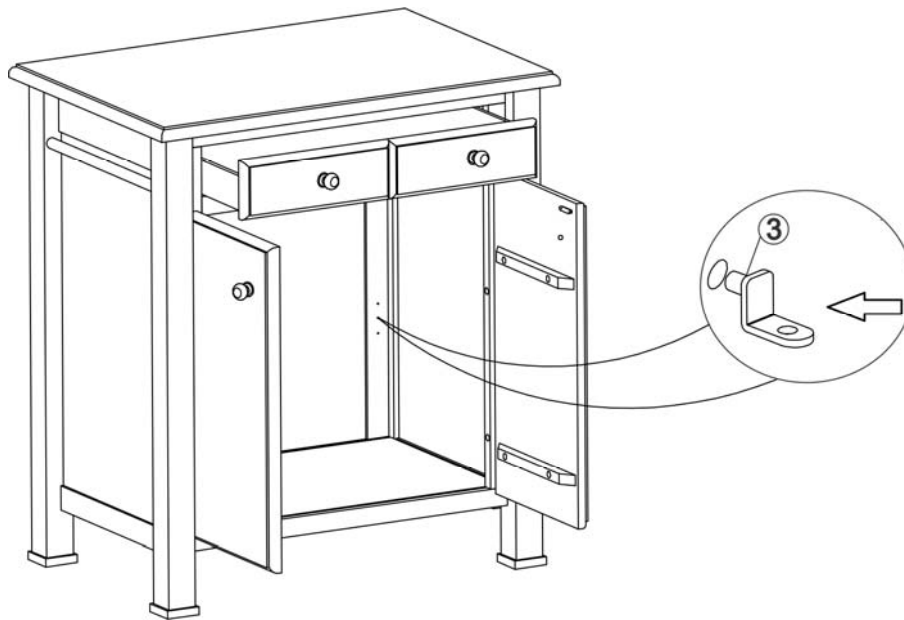

STEP 11

Attach the shelf (G) to the brackets with screws (7). Tighten with a screwdriver.

