

ASSEMBLY INSTRUCTIONS

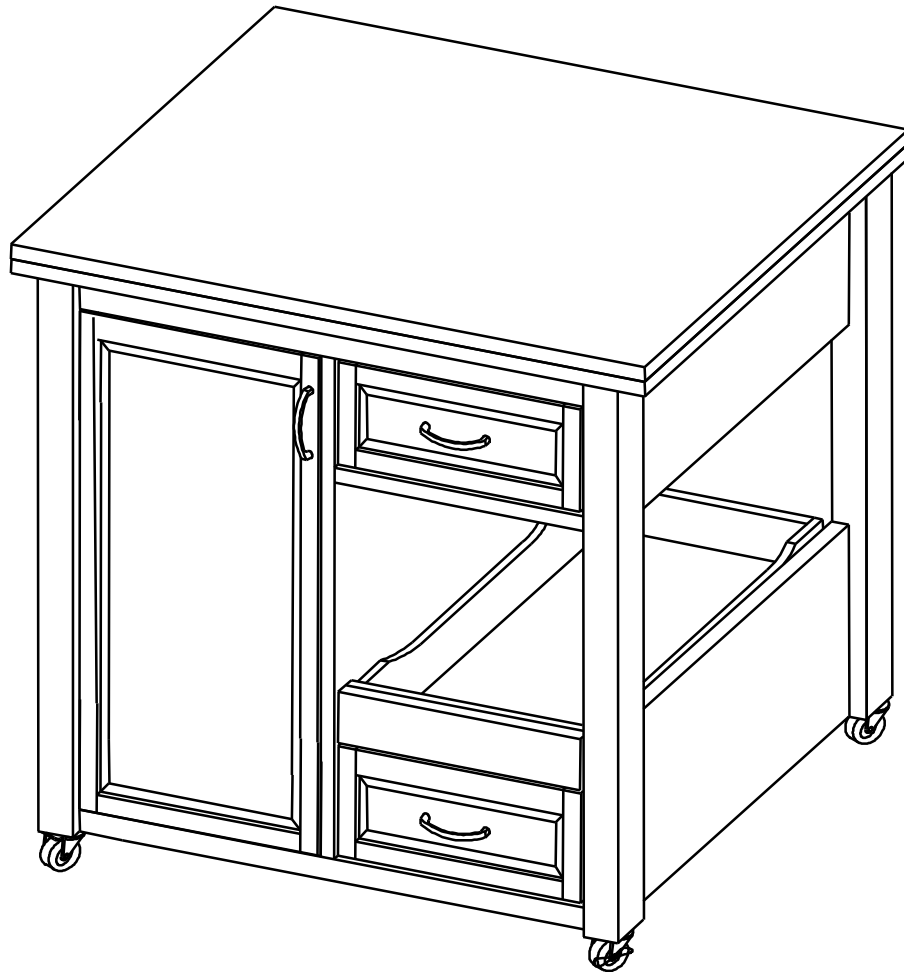

Description : KITCHEN WORKCENTER
Item No. : WC - 7

BEFORE ASSEMBLY

Thank you for purchasing this quality product. This product has been designed for easy assembly and constructed for durability. All parts were checked prior to packaging to insure quality. Prior to beginning assembly, however, make sure all parts and hardware are included and free of obvious defect. If a part is missing or defective, please contact the store where purchased. If hardware is missing, or you need help with assembly, please call toll free 888-944-8396.

IMPORTANT NOTE:

- Place all wooden parts on a clean and smooth surface such as a rug or carpet to avoid the parts from being scratched.
- Remove all wrapping material, including staples & packing straps before you start to assemble.
- DO NOT tighten all screws and bolts until completely assembled.
- Keep all hardware parts out of reach of children.







ASSEMBLY TOOLS REQUIRED

NOT INCLUDED

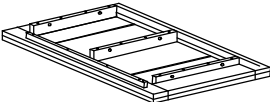

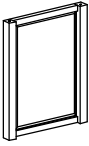
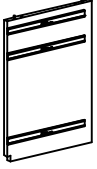
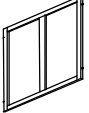
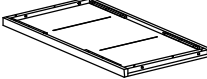

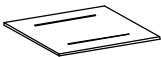
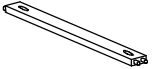
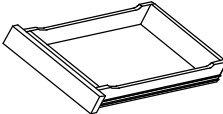
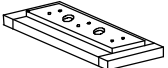
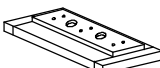
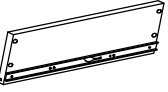
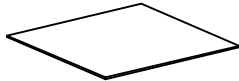







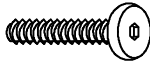

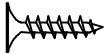
PART LIST

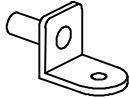
When unpacking, please be careful not to discard any parts with the packaging. Before continuing, please make sure you have the following parts:

NO	Description	Qty	Sketch	NO	Description	Qty	Sketch
A	Top	1		B	Side panel (R)	1	
C	Side panel (L)	1		D	Vertical panel	1	
E	Back panel	1		F	Bottom panel	1	
G	Door	1		H	Shelf panel	1	
I	Rail	1		J	Middle drawer	1	
K	Upper drawer front	1		L	Lower drawer front	1	
M	Drawer side (L - R)	4		N	Drawer bottom	2	
O	Drawer back	2					

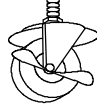
HARDWARE LIST

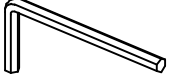
When unpacking, please be careful not to discard any parts with the packaging. Before continuing, please make sure you have all of the following hardware:

NO	Description	Qty	Sketch	NO	Description	Qty	Sketch
1	Bolt (M6x35mm)	12		2	Spring washer (Φ6.5 x 13mm)	12	
3	Flat Washer (Φ6.5 x 19 mm)	12		4	Long screw (M4x30mm)	18	
5	Screw (M3.5 x 15mm)	4		6	Bracket	4	
7	Door pin (Φ5.2/Φ13x1.2mm) (Φ7x10mm)	2		8	Pan head screw (M4 x 20 mm)	6	
9	Handle	3		10	Castor	2	
11	Lock castor	2		12	Allen key (K4)	1	
13	Wrench (19 mm)	1					

STEP 1

Attach side panel (B) to top (A) with bolts (1) and washers (2) and (3) as shown below. Tighten with Allen key (12).

Attach vertical panel (D) to top (A) with bolts (1) and washers (2) and (3) as shown below. Tighten with Allen key (12).

Attach rail (I), side panel (B) and vertical panel (D) with screws (4) as shown below. Tighten with a screwdriver.

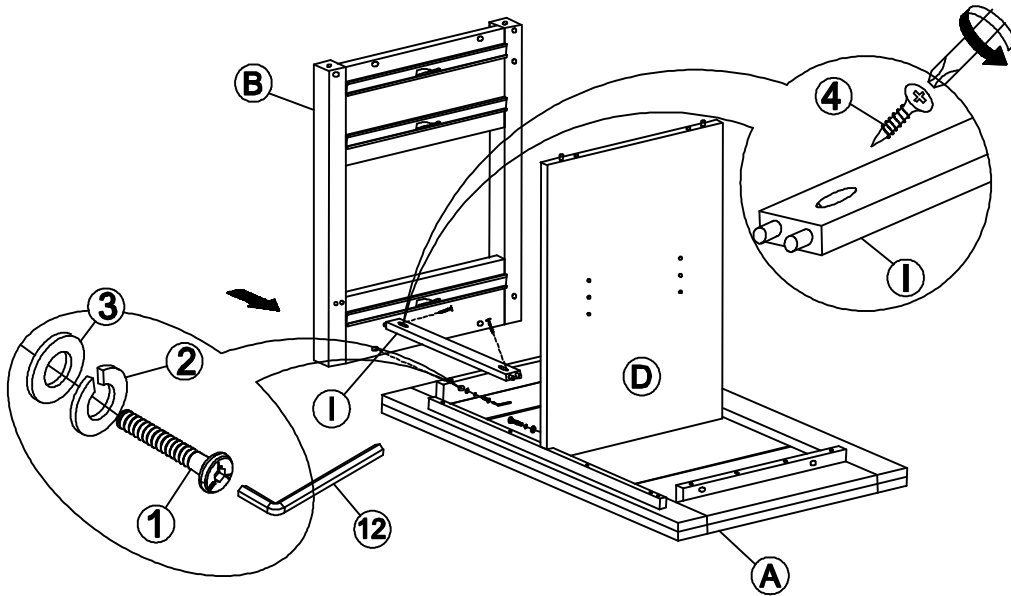

STEP 2

Insert back panel (E) to top (A) and side panel (B) as shown below.

Attach side panel (C) to top (A) with bolts (1) and washers (2) and (3) as shown below. Tighten with Allen key (12).

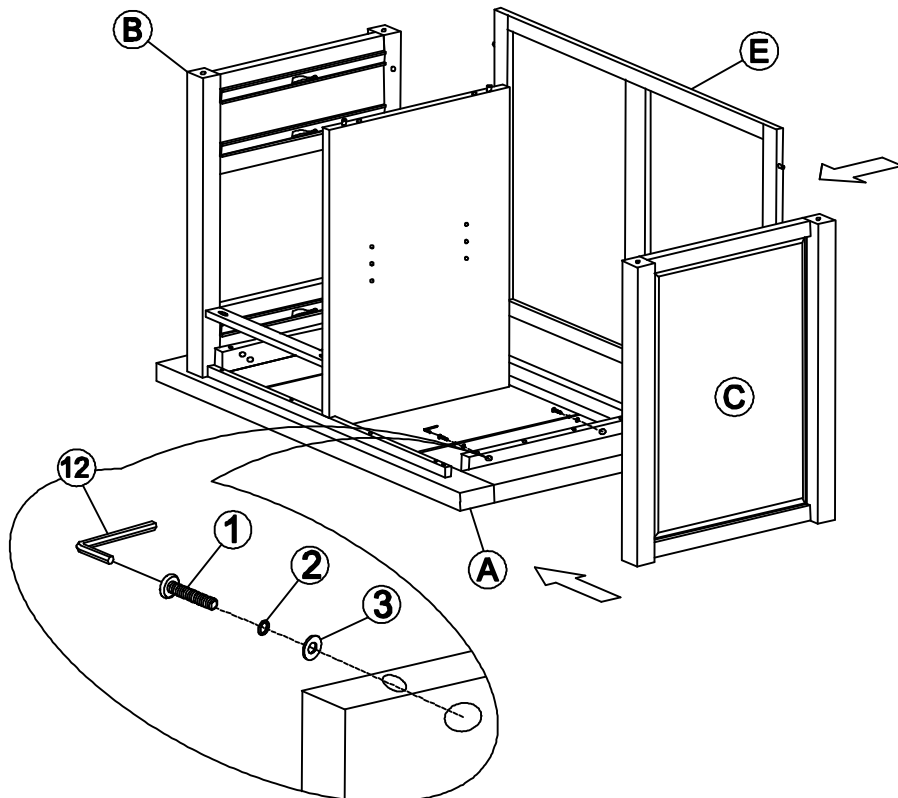

STEP 3

Attach bottom panel (F) to side panels (B) and (C) with bolts (1) and washers (2) and (3) as shown below. Tighten with Allen key (12).

Attach doors (G) to top (A) and bottom (F) with door pins (7).

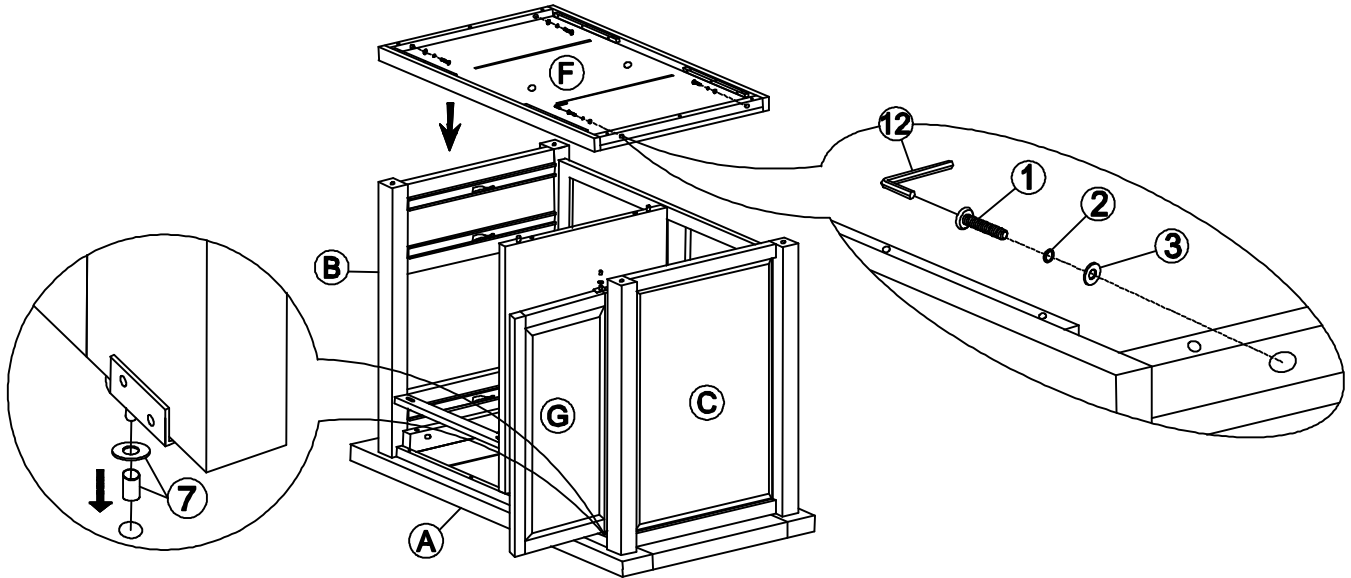

STEP 4

Attach bottom panel (F) to vertical panel (D) with bolts (1) and washers (2) and (3) as shown below. Tighten with Allen key (12).

Attach castors (10) and lock castors (11) to the bottom of legs as shown below. Tighten with the wrench (13).

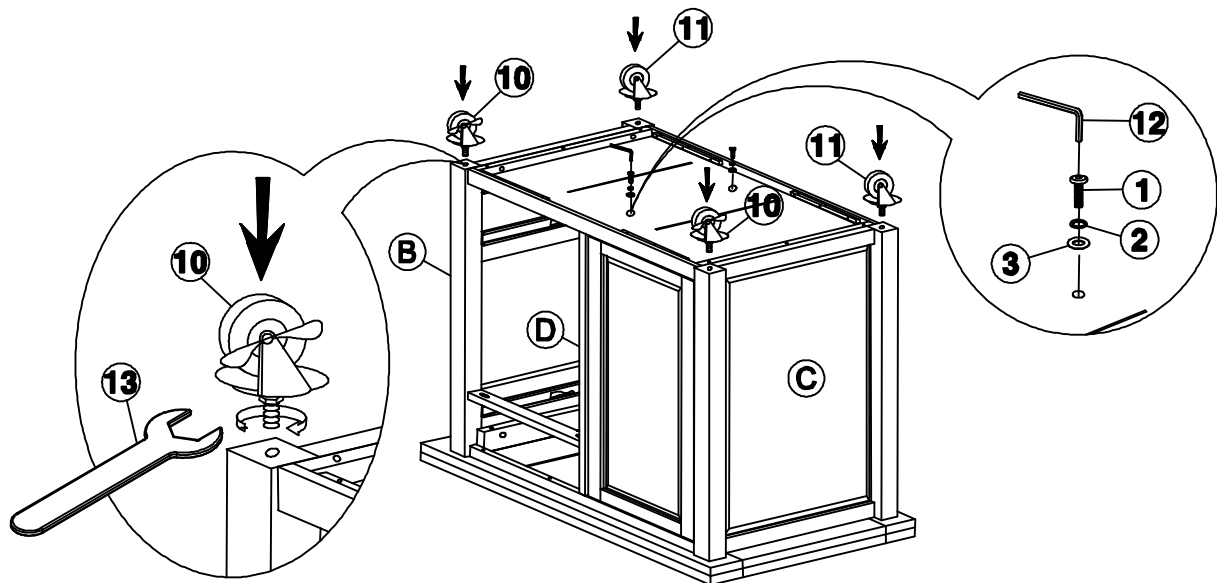

STEP 5

Attach a drawer side (M) to drawer front (K) and drawer back (O) with screws (4). Tighten with a screwdriver. Insert drawer bottom (N) into the grooves at bottom of drawer side (M), drawer front (K) and drawer back (O). Attach the other drawer side (M) to drawer front (K) and drawer back (O) with screws (4). Tighten with a screwdriver. Attach handles (9) to drawer front (K) with screws (8) as shown below. Tighten with a screwdriver.

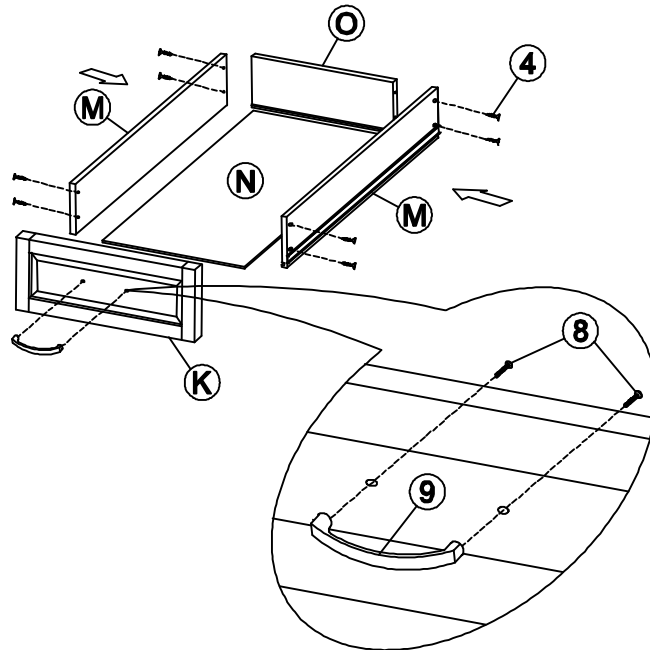

STEP 6

Attach a drawer side (M) to drawer front (L) and drawer back (O) with screws (4). Tighten with a screwdriver. Insert drawer bottom (N) into the grooves at bottom of drawer side (M), drawer front (L) and drawer back (O). Attach the other drawer side (M) to drawer front (L) and drawer back (O) with screws (4). Tighten with a screwdriver. Attach handles (9) to drawer front (L) with screws (8) as shown below. Tighten with a screwdriver.

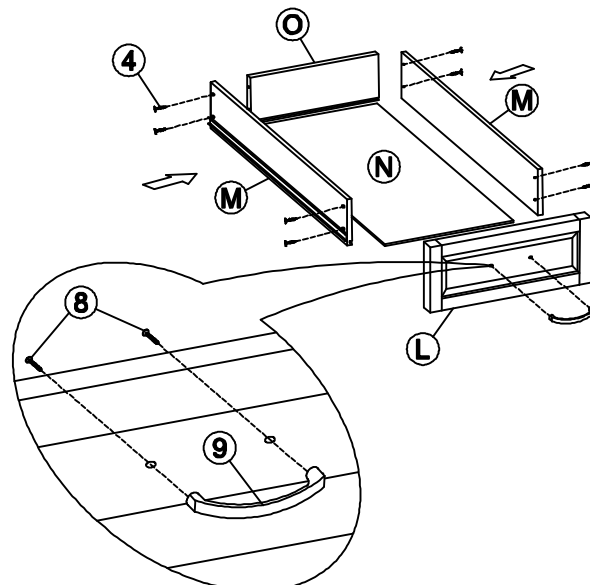

STEP 7

Put the drawers into the unit.

Attach brackets (6) to the unit. Place the shelf (H) on the brackets, and secure with screws (5). Tighten with a screwdriver.

Attach handles (9) to the door with screws (8). Tighten with a screwdriver.

