

ASSEMBLY INSTRUCTIONS

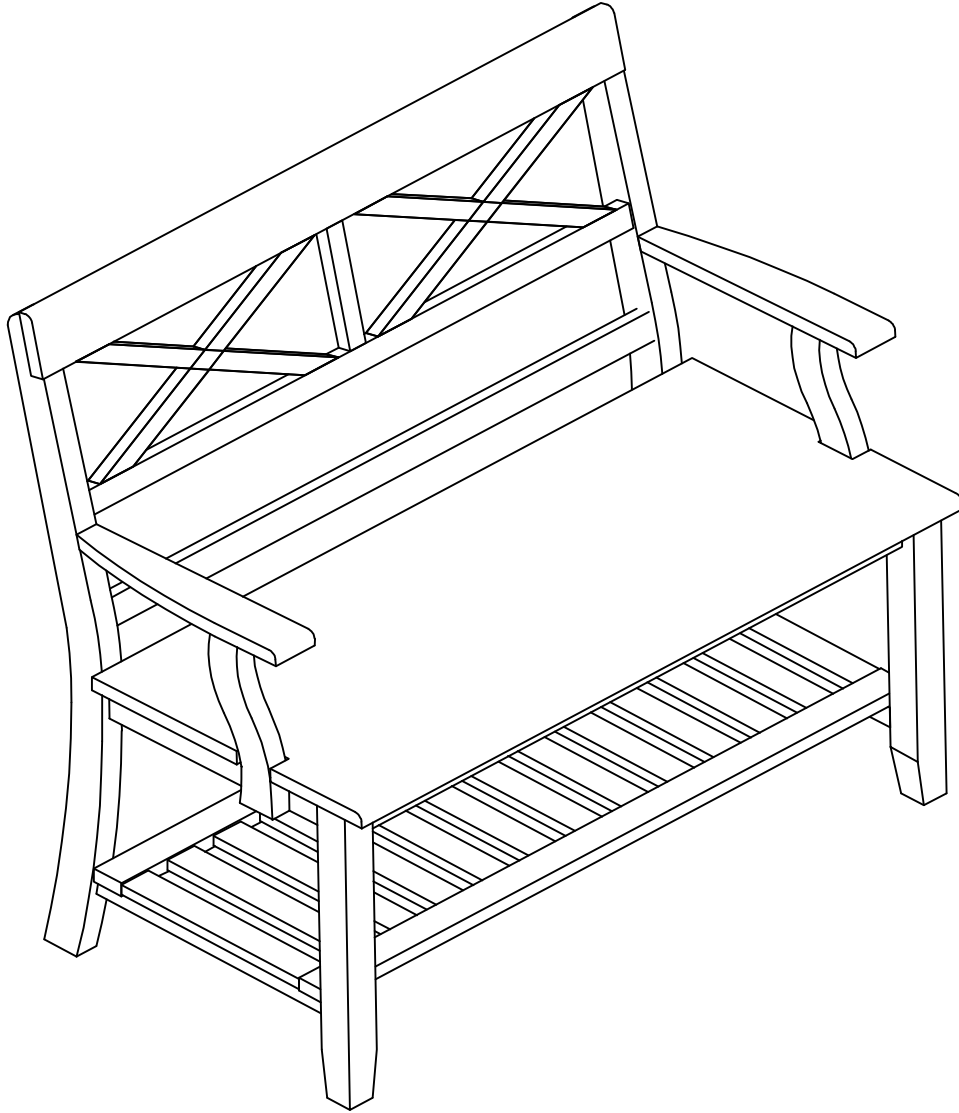

Description : DOUBLE X BACK BENCH 38X18X37.5H
Item No. : BE-1

BEFORE ASSEMBLY

Thank you for purchasing this quality product. This product has been designed for easy assembly and constructed for durability. All parts were checked prior to packaging to insure quality. Prior to beginning assembly, however, make sure all parts and hardware are included and free of obvious defect. If a part is missing or defective, please contact the store where purchased. If hardware is missing, or you need help with assembly, please call toll free 888-944-8396.

IMPORTANT NOTE:

- Place all wooden parts on a clean and smooth surface such as a rug or carpet to avoid the parts from being scratched.
- Remove all wrapping material, including staples & packing straps before you start to assemble.
- DO NOT tighten all screws and bolts until completely assembled.
- Keep all hardware parts out of reach of children.

ASSEMBLY TOOLS REQUIRED

NOT INCLUDED





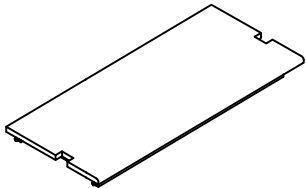
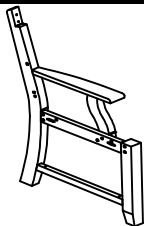
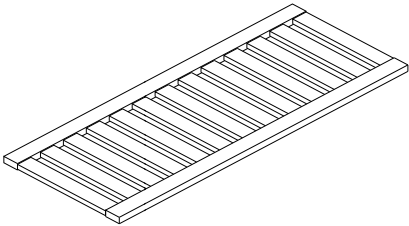
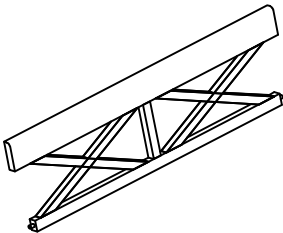
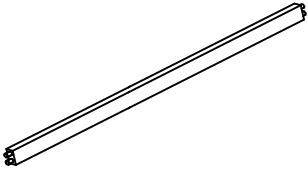

PART LIST

When unpacking, please be careful not to discard any parts with the packaging. Before continuing, please make sure you have the following parts:

| NO | Description | Qty | Sketch | NO | Description | Qty | Sketch |
|----|--------------|-----|------------------------------------------------------------------------------------|----|-----------------------|-----|-------------------------------------------------------------------------------------|
| A | Seat | 1 |  | B | Side frame (L & R) | 2 |  |
| C | Bottom frame | 1 |  | D | Back | 1 |  |
| E | Crossbar | 1 |  | | | | |

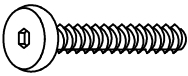
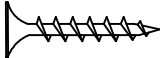
HARDWARE LIST

When unpacking, please be careful not to discard any parts with the packaging. Before continuing, please make sure you have all of the following hardware:

| NO | Description | Qty | Sketch | NO | Description | Qty | Sketch |
|----|------------------------------|-----|-------------------------------------------------------------------------------------|----|---------------------------|-----|---------------------------------------------------------------------------------------|
| 1 | Bolt (M6 X 35mm) | 4 |  | 4 | Screw (M4 x 35mm) | 8 |  |
| 2 | Lock washer (Φ6.0 x 11mm) | 4 |  | 5 | Wood button (Φ10.5mm) | 4 |  |
| 3 | Flat washer (Φ6.5 x 19mm) | 4 |  | 6 | Allen Key (M4 x 110mm) | 1 |  |

ITEMNO.: BE-1
REVISED APR 05, 2016

Printed in Vietnam

STEP 1

Attach right side frame (B) to seat (A) with bolts (1), and washers (2) and (3) as shown below. Tighten with the Allen key (6).

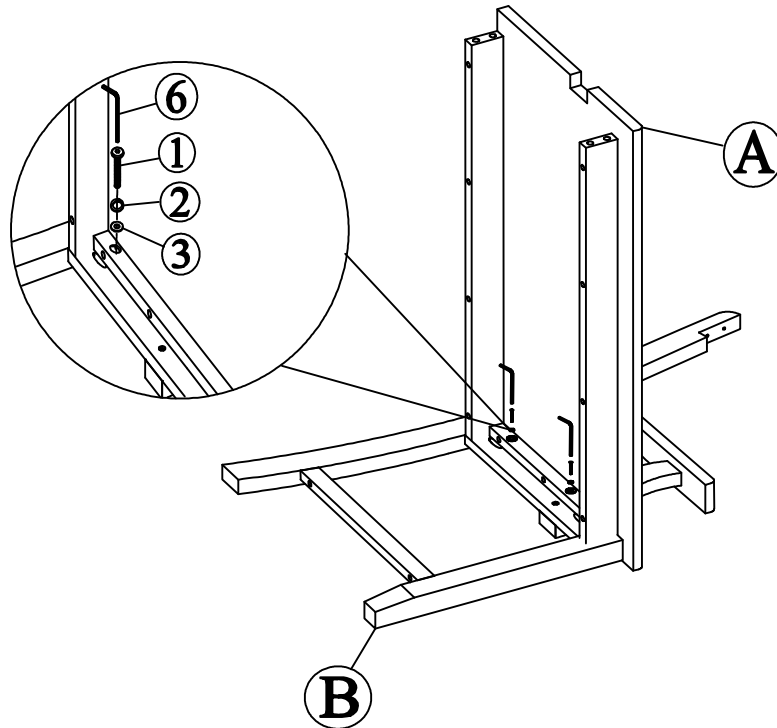

STEP 2

Insert back (D) and cross bar (E) into side frames (B), then attach left side frame (B) to seat (A) with bolts (1), and washers (2) and (3) as shown below. Tighten with the Allen key (6).

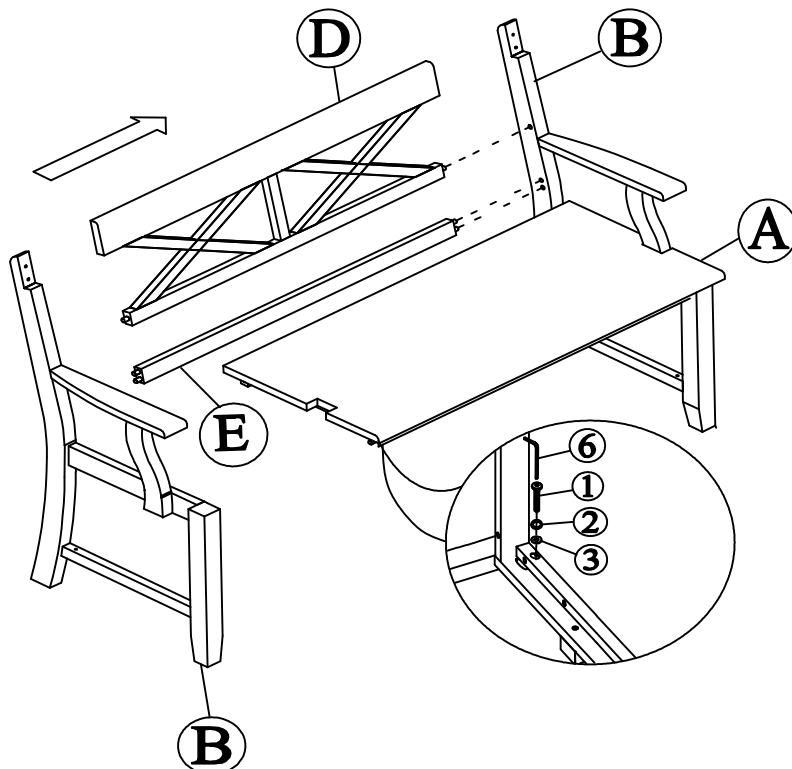

STEP 3

Attach back (D) to side frames (B) with screws (4) as shown below. Tighten with a screwdriver. Then put wood buttons (5) over screws to cover them.

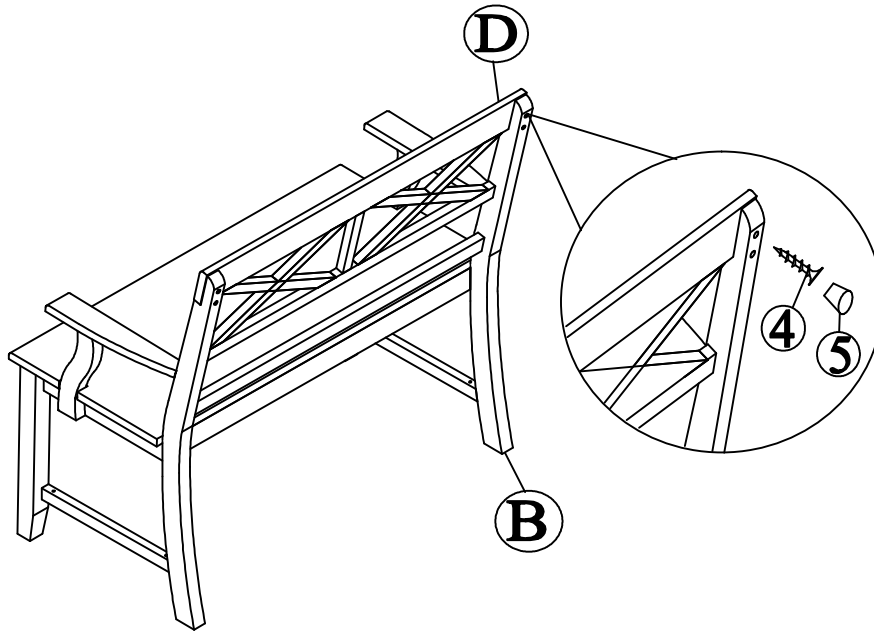

STEP 4

Carefully place the bottom frame (C) on the stretchers of side frames (B) as shown below. Then attach the bottom frame (C) to the unit with screws (4). Tighten with a screwdriver.

