

# ASSEMBLY INSTRUCTIONS

---

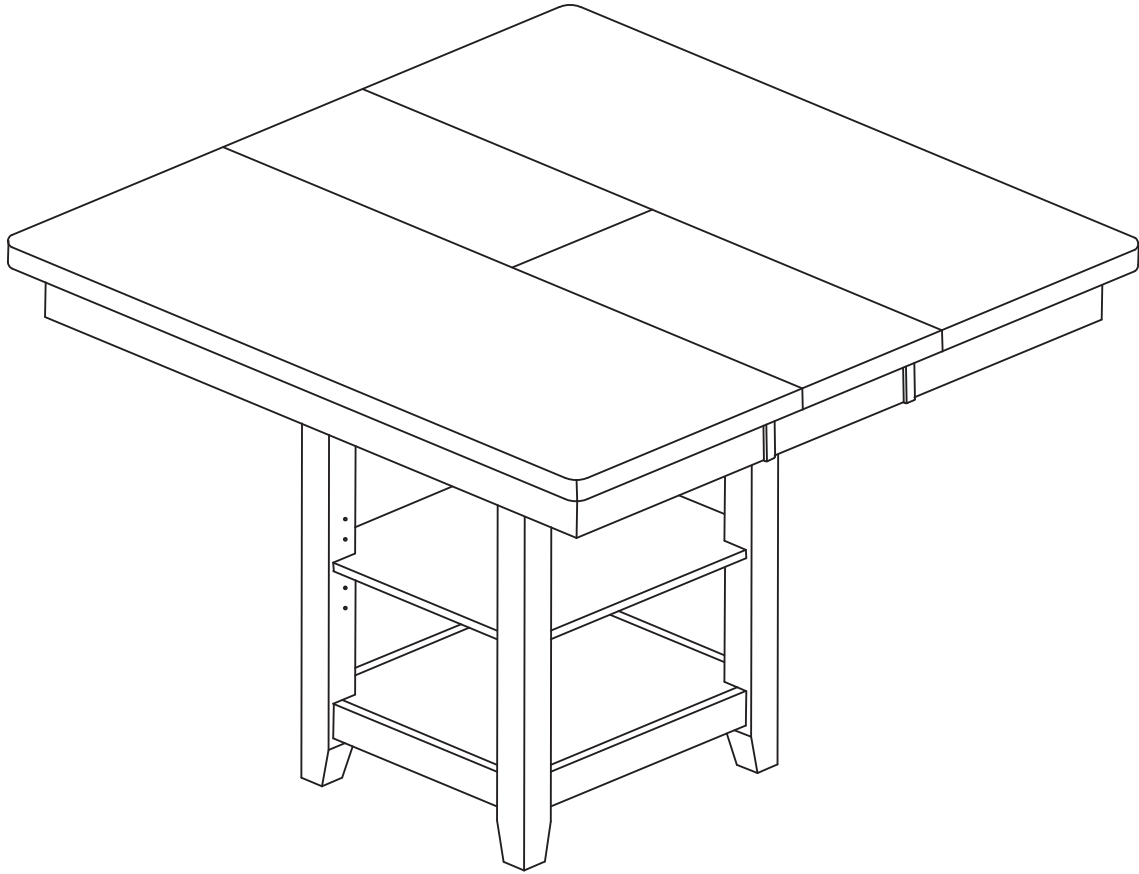

---

Description	: CANYON PEDESTAL GATHERING HEIGHT
Item No.	: T-5436GB AND T-5436XBT (PACKED IN SEPARATE BOX)

ITEM NO: T-5436GB AND T-5436XBT  
(PACKED IN SEPARATE BOX)  
ISSUED NOV 26, 2014

Printed in Vietnam

## BEFORE ASSEMBLY

Thank you for purchasing this quality product. This product has been designed for easy assembly and constructed for durability. All parts were checked prior to packaging to insure quality. Prior to beginning assembly, however, make sure all parts and hardware are included and free of obvious defect. If a part is missing or defective, please contact the store where purchased. If hardware is missing, or you need help with assembly, please call toll free 888-944-8396.

**IMPORTANT NOTE:**

- Place all wooden parts on a clean and smooth surface such as a rug or carpet to avoid the parts from being scratched.
- Remove all wrapping material, including staples & packing straps before you start to assemble.
- DO NOT tighten all screws and bolts until completely assembled.
- Keep all hardware parts out of reach of children.

**WARNING:**

Long exposure to rubber or soft plastic may cause a chemical reaction and damage the finish of your table. Protect the surface of the table with cloth if you are using any product with rubber feet or base.

**ASSEMBLY TOOLS REQUIRED  
NOT INCLUDED**



## PART LIST T-5436XBT

When unpacking, please be careful not to discard any parts with the packaging. Before continuing, please make sure you have the following parts:

NO	Description	Qty	Sketch	NO	Description	Qty	Sketch
A	Top	1					

**ITEM NO: T-5436GB AND T-5436XBT  
(PACKED IN SEPARATE BOX)  
ISSUED NOV 26, 2014**

**Printed in Vietnam**





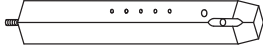
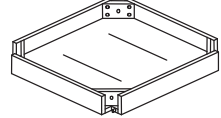
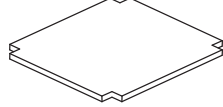



## PART LIST T-5436GB

When unpacking, please be careful not to discard any parts with the packaging. Before continuing, please make sure you have the following parts:

NO	Description	Qty	Sketch	NO	Description	Qty	Sketch
B	Leg (L-R)	4		C	Bottom	1	
D	Shelf	1					

## HARDWARE LIST

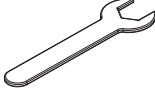
When unpacking, please be careful not to discard any parts with the packaging. Before continuing, please make sure you have all of the following hardware:

NO	Description	Qty	Sketch	NO	Description	Qty	Sketch
1	Hexagon nut (M8x13mm)	4		2	Lock washer (Φ8.5x13mm)	8	
3	Flat washer (Φ8.5x19mm)	8		4	Screw (M3.5x15mm)	4	
5	Shelf support bracket	4		6	Bolt (M8x60mm)	4	
7	Wrench (M13mm)	1		8	Allen Key (4x80mm)	1	

**NOTE : HARDWARE IS PACKED IN CARTON T-5436GB**

ITEM NO: T-5436GB AND T-5436XBT  
(PACKED IN SEPARATE BOX)  
ISSUED NOV 26, 2014

Printed in Vietnam

## STEP 1

Attach bottom panel (C) to the legs (B) with bolts (6), washers (2) and (3), as shown below. Tighten with Allen key (8).

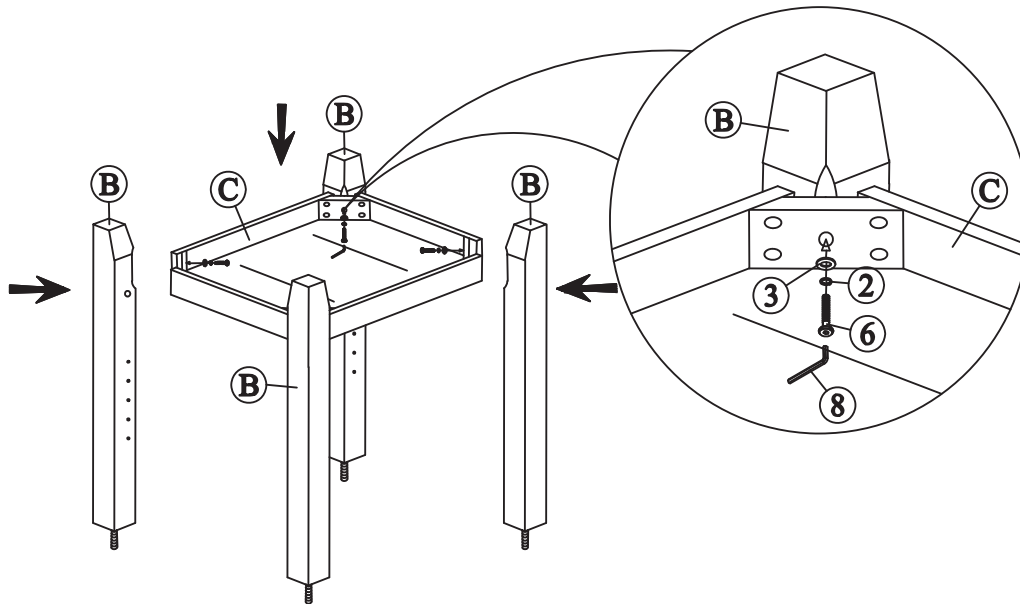

## STEP 2

Attach the legs (B) to the Top (A) with washers (2) , (3) and nuts (1), as shown below. Tighten with the wrench (7).

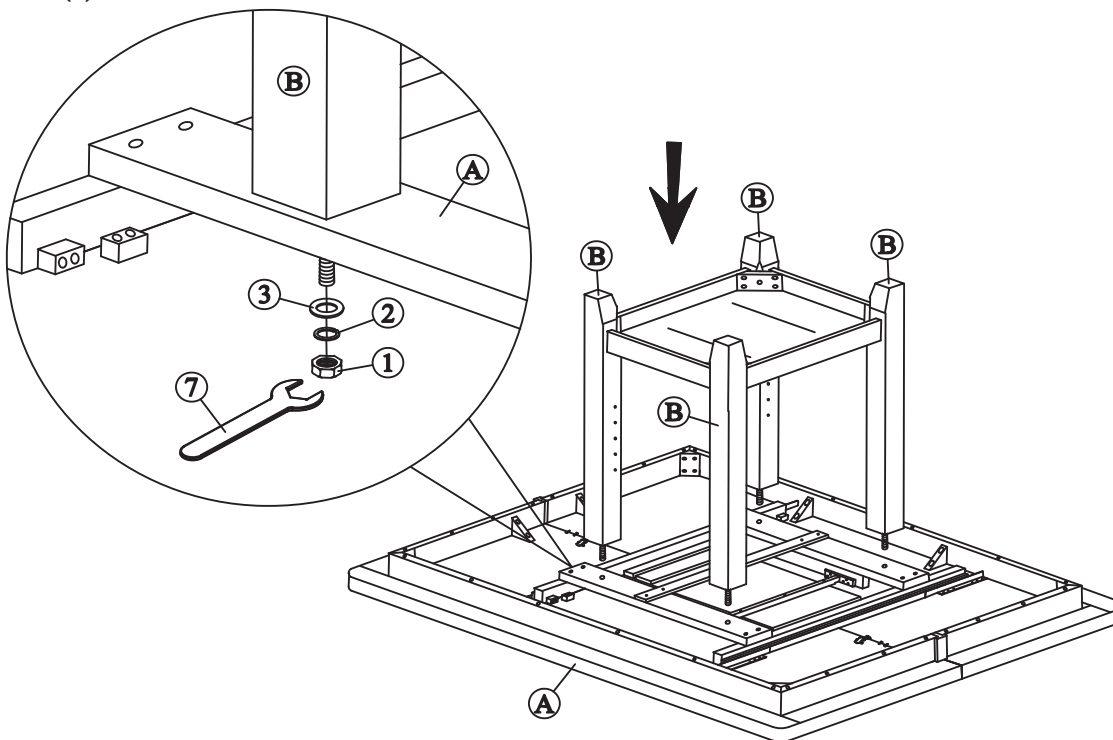

ITEM NO: T-5436GB AND T-5436XBT  
(PACKED IN SEPARATE BOX)  
ISSUED NOV 26, 2014

Printed in Vietnam

## STEP 3

Insert brackets (5) into the unit as shown below. Place shelf (D) on the brackets and attach with screws (4). Tighten with a screwdriver.

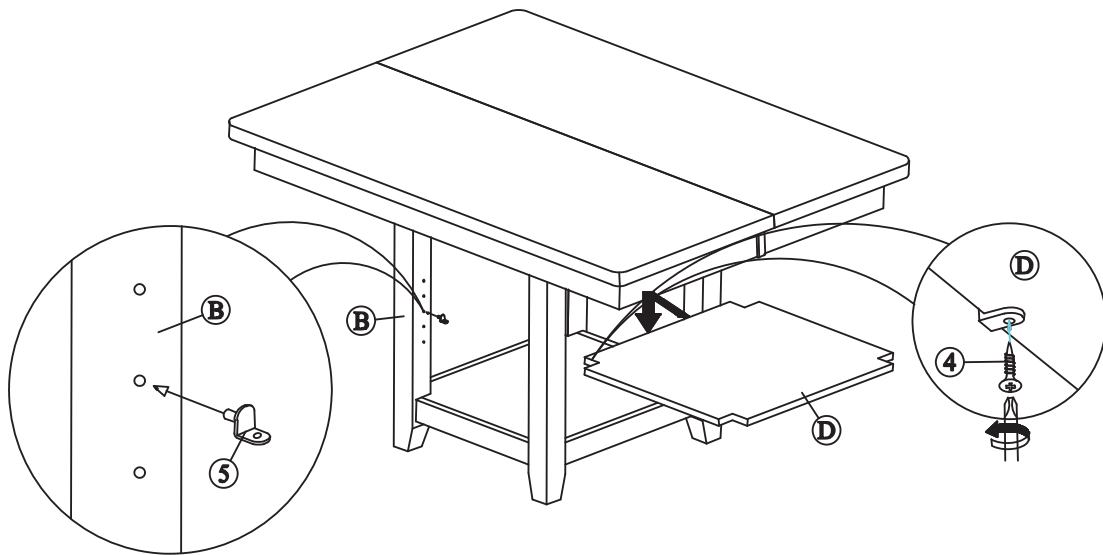

## STEP 4

Unlock the table top from both sides underneath of the top as shown below. Pull the 2 parts of the table top apart.

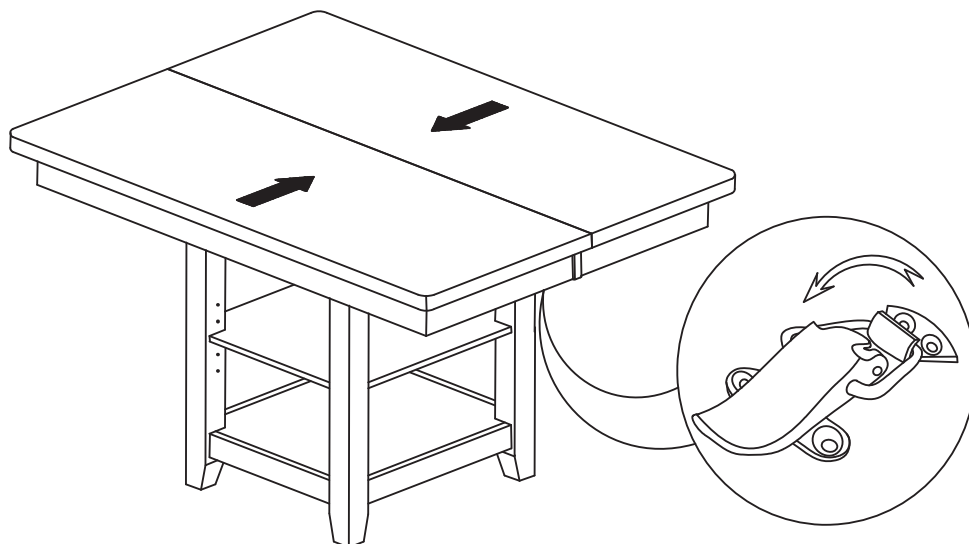

ITEM NO: T-5436GB AND T-5436XBT  
(PACKED IN SEPARATE BOX)  
ISSUED NOV 26, 2014

Printed in Vietnam

## STEP 5

Place the leaves in the center of the open table top. Push the table top closed. Lock the mechanism underneath 2 sides of the table top as shown below.

