

ASSEMBLY INSTRUCTIONS

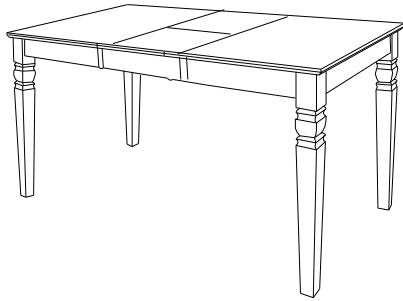

T-4060JXBT/T-30J

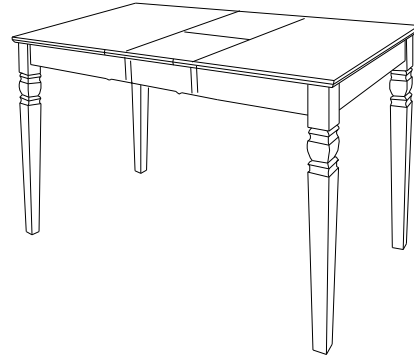

T-4060JXBT/T-36J

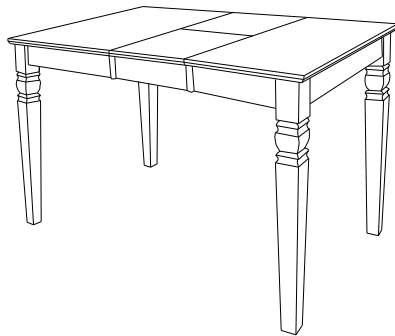

T-4040JXBT/T-30J

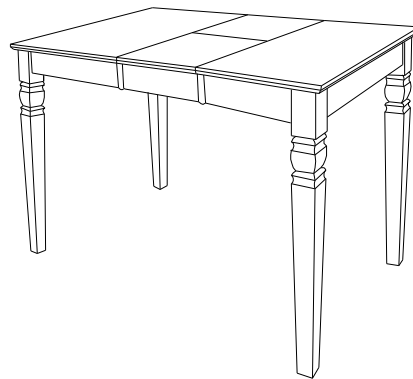

T-4040JXBT/T-36J

Description : TABLE

Item No. : T-4040JXBT OR T-4060JXBT & T-30J OR T-36J

ITEM NO.: T-4040JXBT OR T-4060JXBT & T-30J OR T-36J
REVISED AUG 19, 2014

Printed in Vietnam

THIS ITEM IS PACKED IN 2 CARTONS

BEFORE ASSEMBLY

Thank you for purchasing this quality product. This product has been designed for easy assembly and constructed for durability. All parts were checked prior to packaging to insure quality. Prior to beginning assembly, however, make sure all parts and hardware are included and free of obvious defect. If a part is missing or defective, please contact the store where purchased. If hardware is missing, or you need help with assembly, please call toll free 888-944-8396.

IMPORTANT NOTE:

- Place all wooden parts on a clean and smooth surface such as a rug or carpet to avoid the parts from being scratched.
- Remove all wrapping material, including staples & packing straps before you start to assemble.
- DO NOT tighten all screws and bolts until completely assembled.
- Keep all hardware parts out of reach of children.

WARNING:

Long exposure to rubber or soft plastic may cause a chemical reaction and damage the finish of your table. Protect the surface of the table with cloth if you are using any product with rubber feet or base.

PART LIST T-4040JXBT OR T-4060JXBT

When unpacking, please be careful not to discard any parts with the packaging. Before continuing, please make sure you have the following parts:

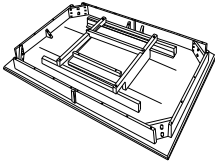
NO	Description	Qty	Sketch	NO	Description	Qty	Sketch
A	Table top	1					





PART LIST T-30J OR T-36J

When unpacking, please be careful not to discard any parts with the packaging. Before continuing, please make sure you have the following parts:

NO	Description	Qty	Sketch	NO	Description	Qty	Sketch
B	Legs	4					

HARDWARE LIST

When unpacking, please be careful not to discard any parts with the packaging. Before continuing, please make sure you have all of the following hardware:

NO	Description	Qty	Sketch	NO	Description	Qty	Sketch
1	Hexagon nut (M8x13mm)	8		3	Flat washer (Φ8.5x19mm)	8	
2	Lock washer (Φ8.5x13mm)	8		4	Wrench (13mm)	1	

NOTE: HARDWARE IS PACKED IN CARTON OF LEGS T-30J OR T-36J

STEP 1

Attach legs (B) to the top (A) with flat washers (2), lock washers (3), and nuts (1) as shown below. Tighten with the wrench (4).

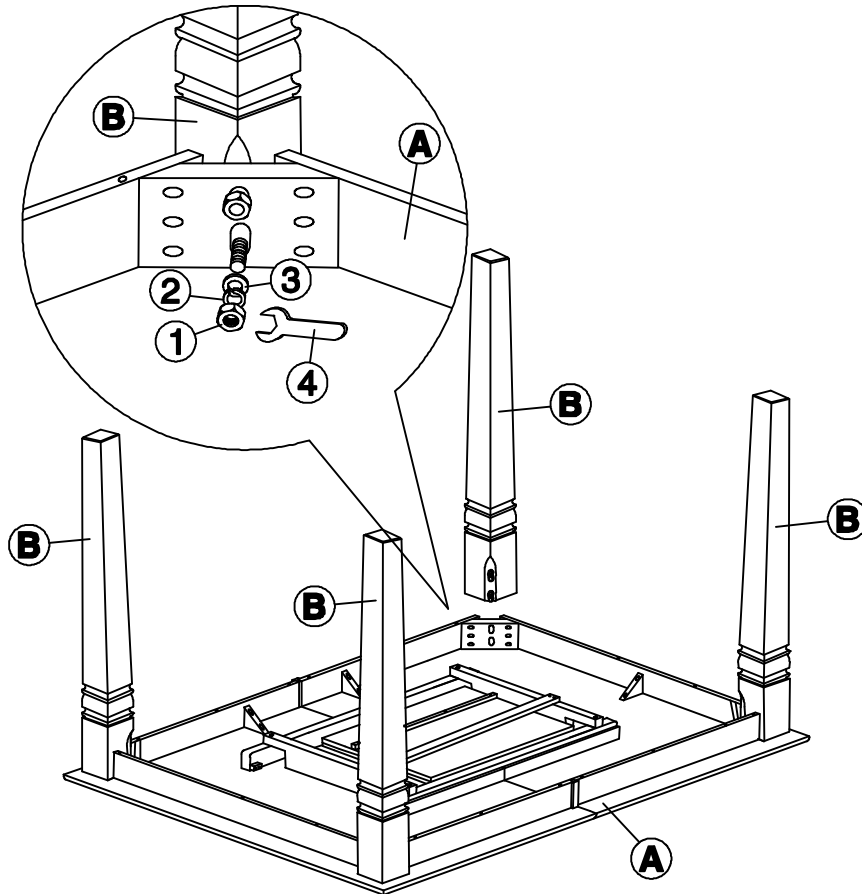

STEP 2

Unlock the table top from both sides underneath of the top as shown below.
Pull the 2 parts of the table top apart.

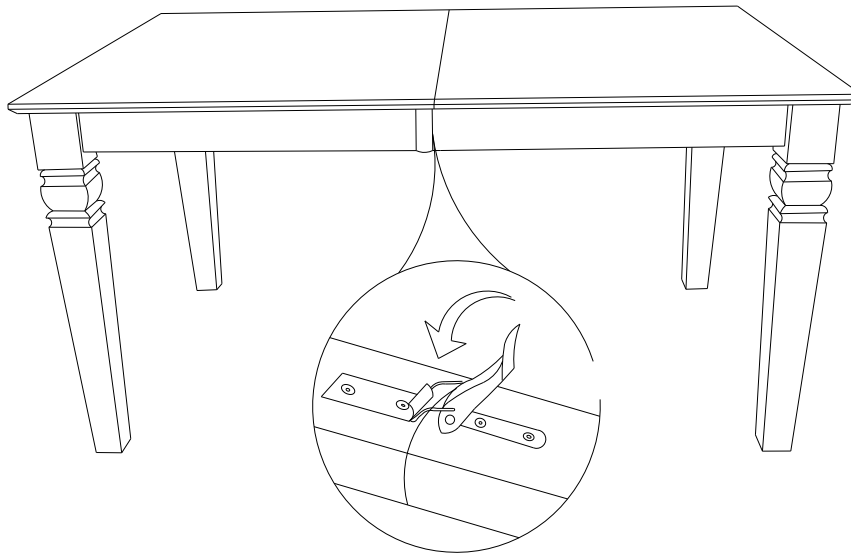

STEP 3

Place the leaf in the center of the open table top. Push the table top closed. Lock the mechanism underneath 2 sides of the table top as shown below.

