

# ASSEMBLY INSTRUCTIONS

---

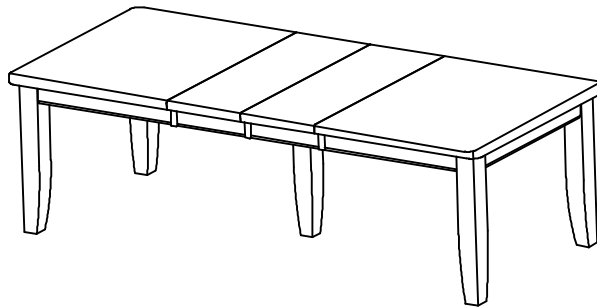

T-4066XXTT AND T-53B

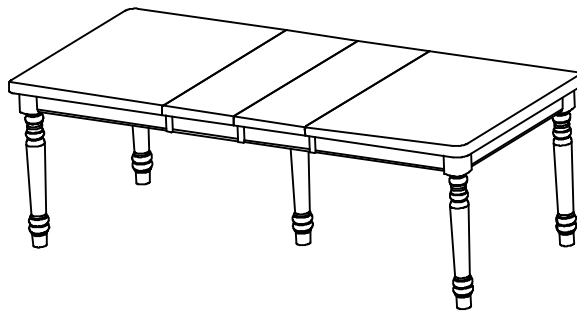

T-4066XXTT AND T-51B

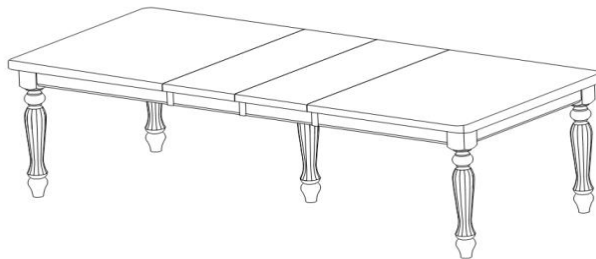

T-4066XXTT AND T-52B

---

Description : FARMHOUSE EXTENSION TABLE  
Item No : T-4066XXTT AND T-51B OR T-52B OR T-53B  
(PACKED IN SEPARATE BOX)

**ITEM : T-4066XXTT AND T-51B OR T-52B OR T-53B**

(PACKED IN SEPARATE BOX)

**REVISED SEP 16, 2014**

**Printed in Vietnam**

## BEFORE ASSEMBLY

Thank you for purchasing this quality product. This product has been designed for easy assembly and constructed for durability. All parts were checked prior to packaging to insure quality. Prior to beginning assembly, however, make sure all parts and hardware are included and free of obvious defect. If a part is missing or defective, please contact the store where purchased. If hardware is missing, or you need help with assembly, please call toll free 888-944-8396.

**IMPORTANT NOTE:**

- Place all wooden parts on a clean and smooth surface such as a rug or carpet to avoid the parts from being scratched.
- Remove all wrapping material, including staples & packing straps before you start to assemble.
- DO NOT tighten all screws and bolts until completely assembled.
- Keep all hardware parts out of reach of children.

**WARNING:**

Long exposure to rubber or soft plastic may cause a chemical reaction and damage the finish of your table. Protect the surface of the table with cloth if you are using any product with rubber feet or base.

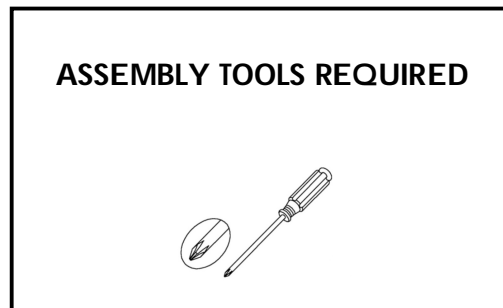

## PARTS LIST

When unpacking, please be careful not to discard any parts with the packaging. Before continuing, please make sure you have the following parts:

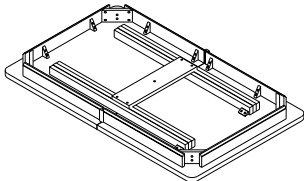
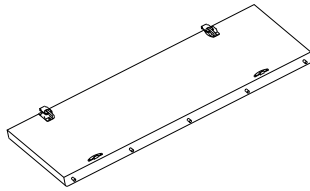
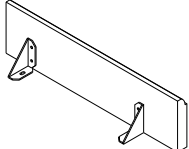

NO	Description	Q'ty	Sketch	NO	Description	Q'ty	Sketch
A	Top	1		B	TABLE LEAF	2	
C	LEAF APRONS	Lx2pcs Rx2pcs					

**ITEM : T-4066XXIT AND T-51B OR T-52B OR T-53B**  
(PACKED IN SEPARATE BOX)

**Printed in Vietnam**



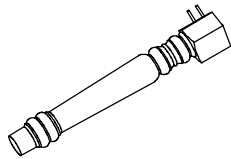
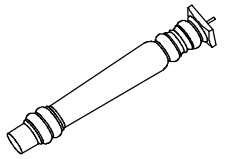
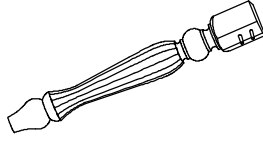
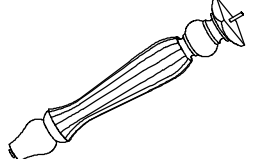
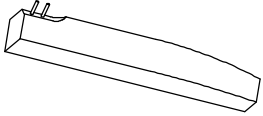

**REVISED SEP 16, 2014**

## PARTS LIST LEGS T-51B OR T-52B OR T-53B

NO	Description	Qty	Sketch	NO	Description	Qty	Sketch
D	LEGS (T-51B)	4		E	CENTER LEGS (T-51B)	1	
D	LEGS (T-52B)	4		E	CENTER LEGS (T-52B)	1	
D	LEGS (T-53B)	4		E	CENTER LEGS (T-53B)	1	

## HARDWARE LIST

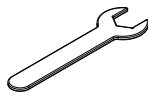
When unpacking, please be careful not to discard any parts with the packaging. Before continuing, please make sure you have all of the following hardware:

NO	Description	Q'ty	Sketch	NO	Description	Q'ty	Sketch
1	Flat washer ( $\Phi 8.5 \times \Phi 19 \text{mm}$ )	9		2	Hexagon nuts (M8x13mm)	9	
3	Lock washer ( $\Phi 8.5 \times \Phi 13 \text{mm}$ )	9		4	Wrench (M8x13mm)	1	
5	Wood screw (M3.5x15mm)	8					

**NOTE: HARDWARE IS PACKED IN CARTON OF LEGS T-51B, T-52B, T-53B**

**ITEM : T-4066XXIT AND T-51B OR T-52B OR T-53B**  
(PACKED IN SEPARATE BOX)

**Printed in Vietnam**

**REVISED SEP 16, 2014**

# STEP 1

Attach legs (D) and (E) to the top (A) with washers (3) and (2), and nuts (1) as shown below. Tighten with the wrench (4).

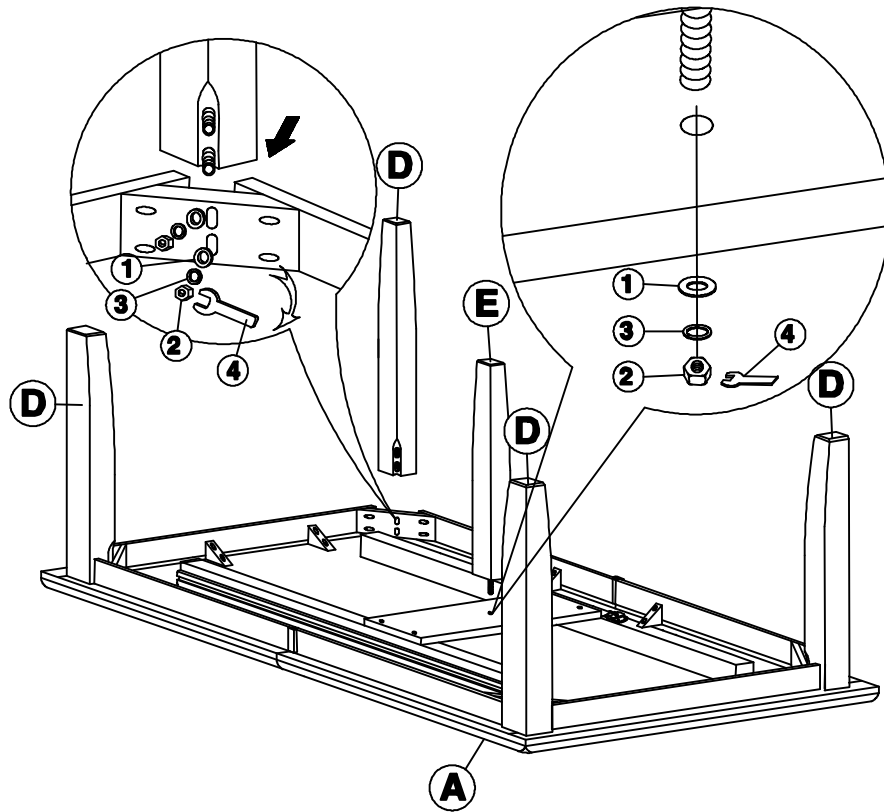

ITEM : T-4066XXIT AND T-51B OR T-52B OR T-53B  
(PACKED IN SEPARATE BOX)  
REVISED SEP 16, 2014

Printed in Vietnam

## STEP 2

Attach aprons (C) to leaves (B) with screws (5). Tighten with the screwdriver

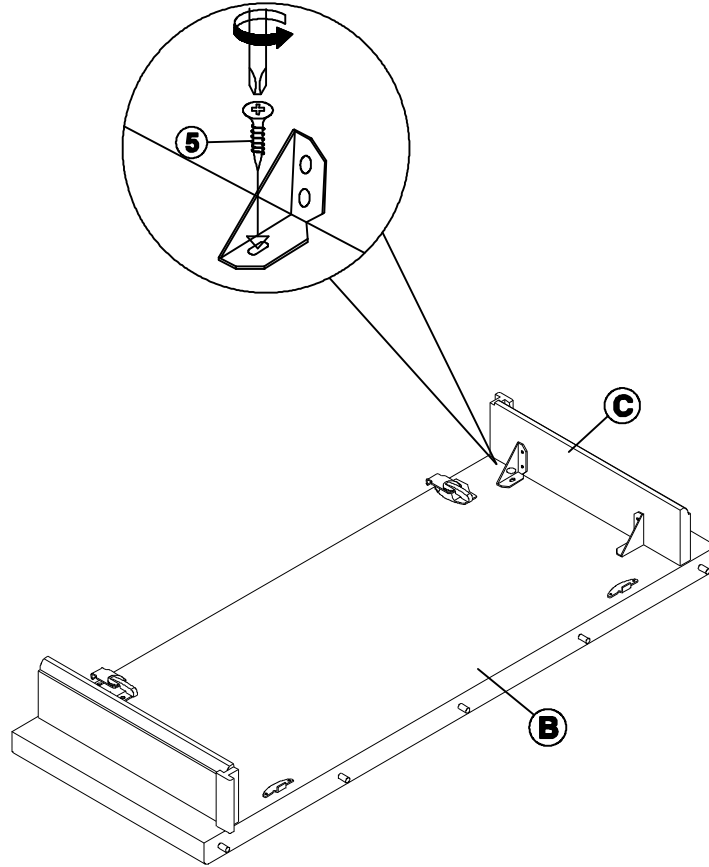

## STEP 3

Unlock the table top from both sides underneath of the top as shown below.  
Pull the 2 parts of the table top apart.

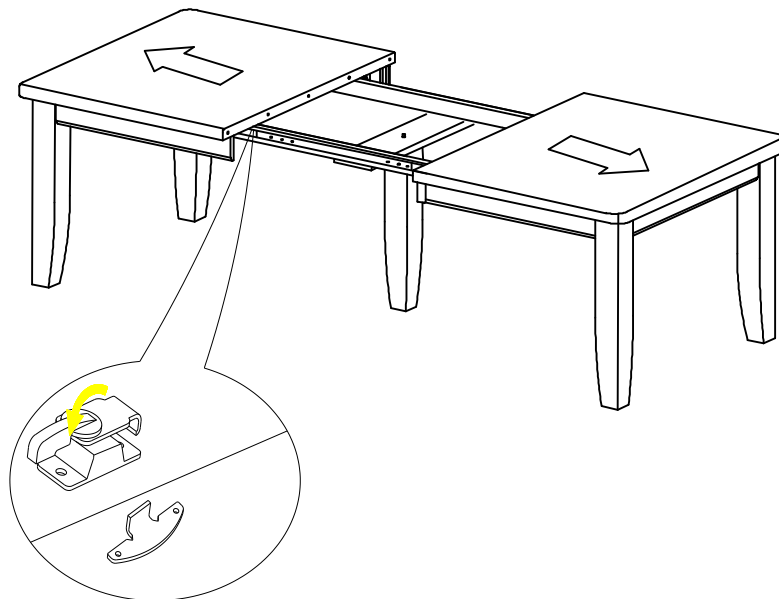

ITEM : T-4066XXIT AND T-51B OR T-52B OR T-53B  
(PACKED IN SEPARATE BOX)  
REVISED SEP 16, 2014

Printed in Vietnam

## STEP 4

Place the leaves (B) in the center of the top as shown below.

Push the table top closed. Lock the mechanism underneath 2 sides of the table top as shown below.

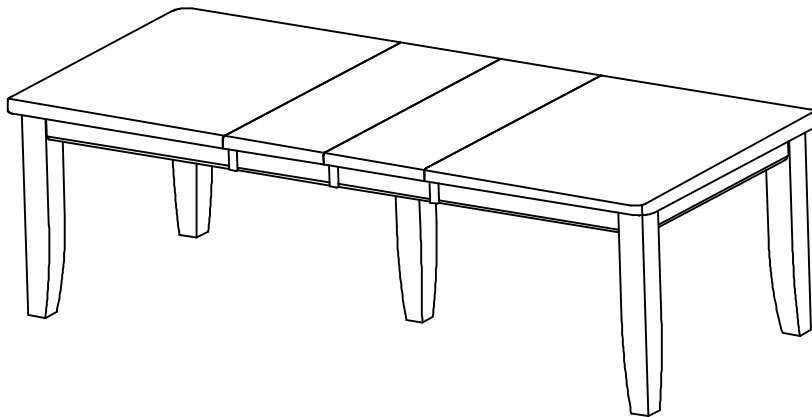
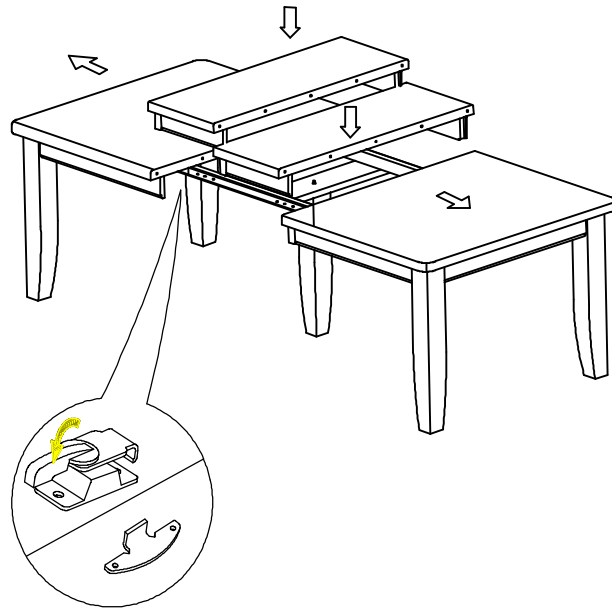

ITEM : T-4066XXIT AND T-51B OR T-52B OR T-53B

(PACKED IN SEPARATE BOX)

REVISED SEP 16, 2014

Printed in Vietnam