

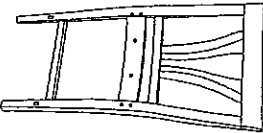









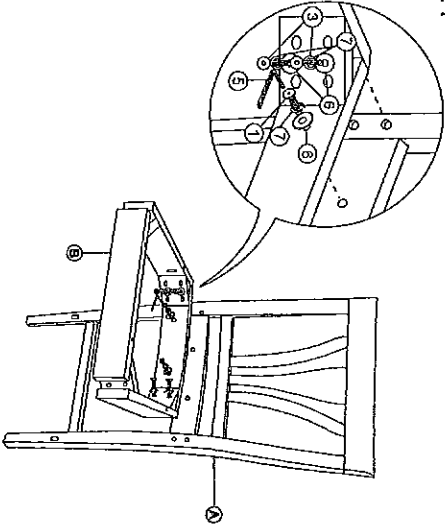
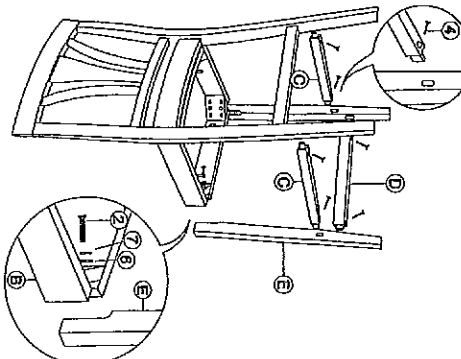
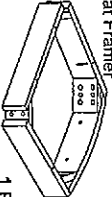

 TOLL FREE : 1 888 944 8366

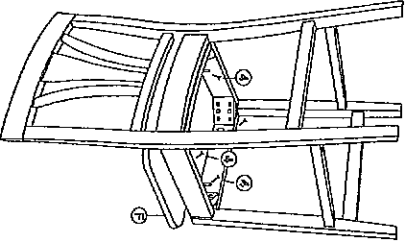
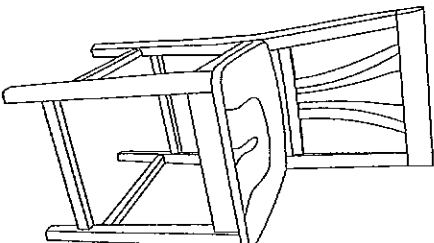
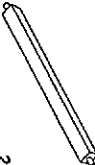
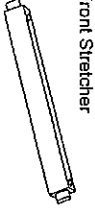
LIST OF PARTS	LIST OF HARDWARE		
<p>A- Chair back 1 PC</p> 	<p>1- Short JCBC bolt </p> <p>2- Medium JCBC bolt </p> <p>3- Long JCBC bolt </p> <p>4- Screw </p>	<p>Step. 1</p> 	<p>Step. 2</p> 
<p>B- Seat Frame 1 PC</p> 	<p>4x35mm (10 PCS) 5- Allen key </p>	<p>Step. 3</p> 	<p>Step. 4</p> 
<p>C- Side stretcher (L-R) 2 PCS</p> 	<p>6- Flat Washer </p>	<p>4 mm (1 PC) 7- Lock Washer </p>	
<p>D- Front Stretcher 1 PC</p> 	<p>6- Flat Washer </p>		
<p>E- Front leg (L-R) 2 PCS</p> 	<p>6- Flat Washer </p>		
<p>F- Chair seat 1 PC</p> 	<p>7- Lock Washer </p>		