

ASSEMBLY INSTRUCTIONS

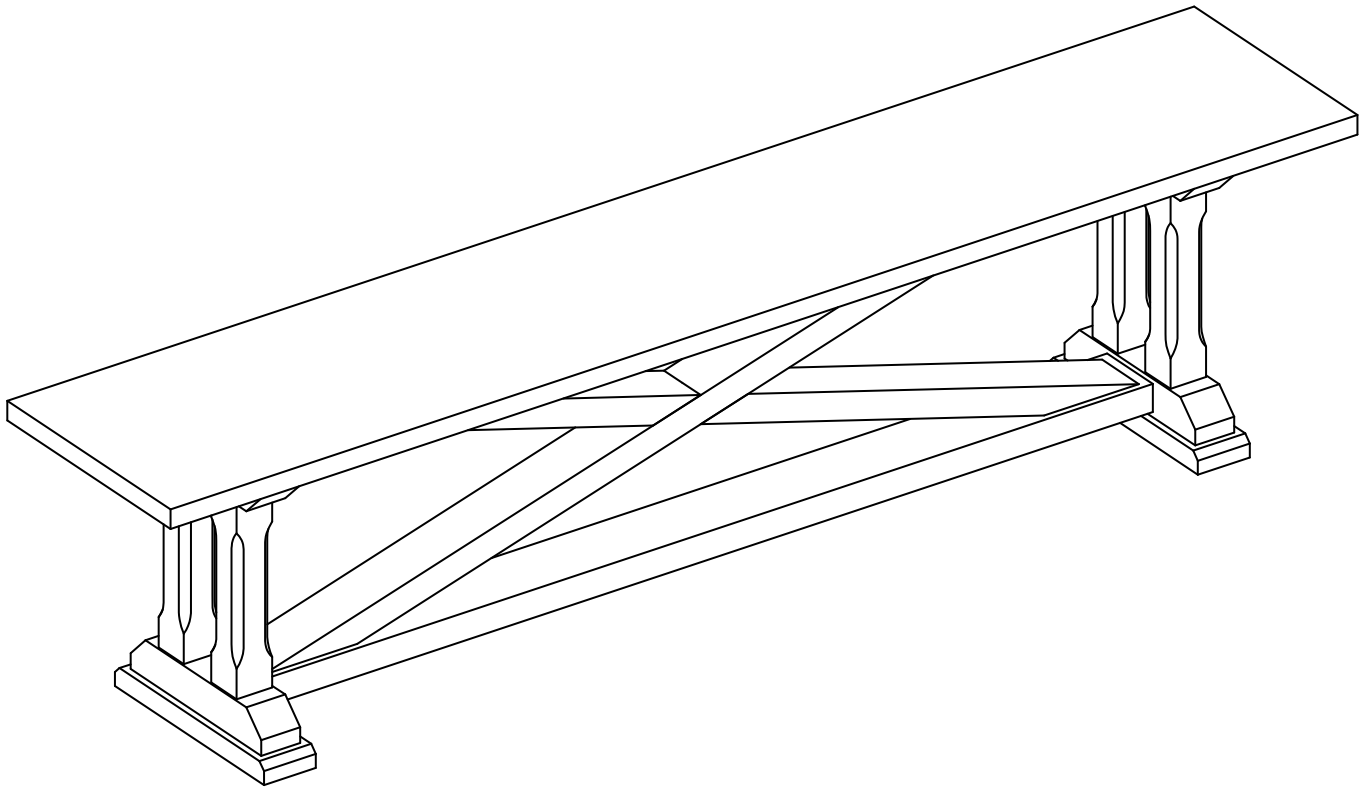

Description : 72 IN ALEXA TRESTLE BENCH
Item No. : BE-172TA AND BE-172TB

ITEM NO.: BE-172TA AND BE-172TB
ISSUED NOV 08, 2018

Printed in Vietnam
THIS ITEM IS PACKED IN TWO CARTONS

BEFORE ASSEMBLY

Thank you for purchasing this quality product. This product has been designed for easy assembly and constructed for durability. All parts were checked prior to packaging to insure quality. Prior to beginning assembly, however, make sure all parts and hardware are included and free of obvious defect. If a part is missing or defective, please contact the store where purchased. If hardware is missing, or you need help with assembly, please call toll free 888-944-8396.

IMPORTANT NOTE:

- Place all wooden parts on a clean and smooth surface such as a rug or carpet to avoid the parts from being scratched.
- Remove all wrapping material, including staples & packing straps before you start to assemble.
- DO NOT tighten all screws, bolts until completely assembled.
- Keep all hardware parts out of reach of children.

PART LIST T-172TA

When unpacking, please be careful not to discard any parts with the packaging. Before continuing, please make sure you have the following parts:

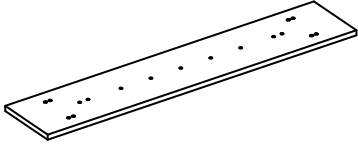
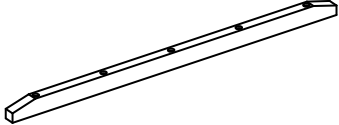
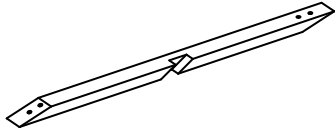
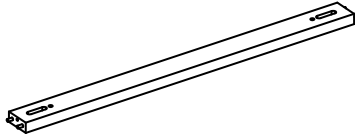
NO	Description	Qty	Sketch	NO	Description	Qty	Sketch
A	Top	1		B	Support bar	1	
C	X-Base	2		D	Cross bar	1	





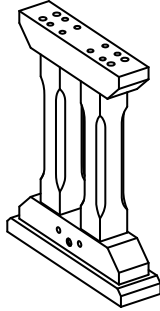

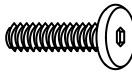

PART LIST T-172TB

When unpacking, please be careful not to discard any parts with the packaging. Before continuing, please make sure you have the following parts:

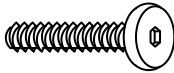
NO	Description	Qty	Sketch
E	Base	2	

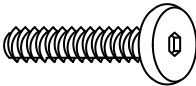
HARDWARE LIST

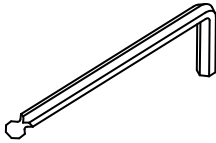
When unpacking, please be careful not to discard any parts with the packaging. Before continuing, please make sure you have all of the following hardware:

NO	Description	Qty	Sketch	NO	Description	Qty	Sketch
1	Short Bolt (M6 x 35mm)	8		6	Large Spring washer (Φ8.5 x 13mm)	8	
2	Medium Bolt (M6 x 55mm)	7		7	Large Flat Washer (Φ8.5 x 19mm)	8	
3	Long Bolt (M8 x 60mm)	8		8	U-Washer	2	
4	Small Spring washer (Φ6.5 x 11mm)	13		9	Allen key (M4 x 30mm x 110mm)	1	
5	Small Flat Washer (Φ6.5 x 13mm)	13					

NOTE: HARDWARE IS PACKED IN CARTON BE-172TB.

**ITEM NO.: BE-172TA AND BE-172TB
ISSUED NOV 08, 2018**

**Printed in Vietnam
THIS ITEM IS PACKED IN TWO CARTONS**

STEP 1

Attach support bar (B) to top (A) with bolts (2), and washers (4) and (5) as shown below. Tighten with Allen key (9).

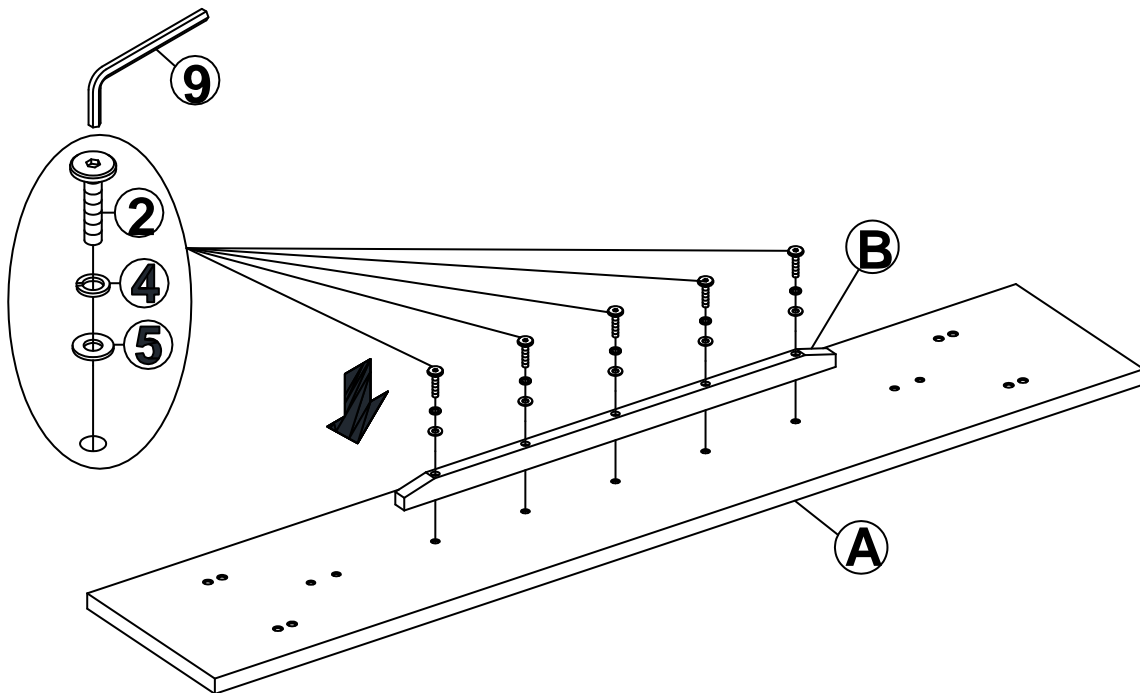

STEP 2

Attach X-Base (C) to the top (A) and attach crossbar (D) to X-Base (C) with bolts (1), and washers (4) and (5) as shown below. Tighten with Allen key (9).

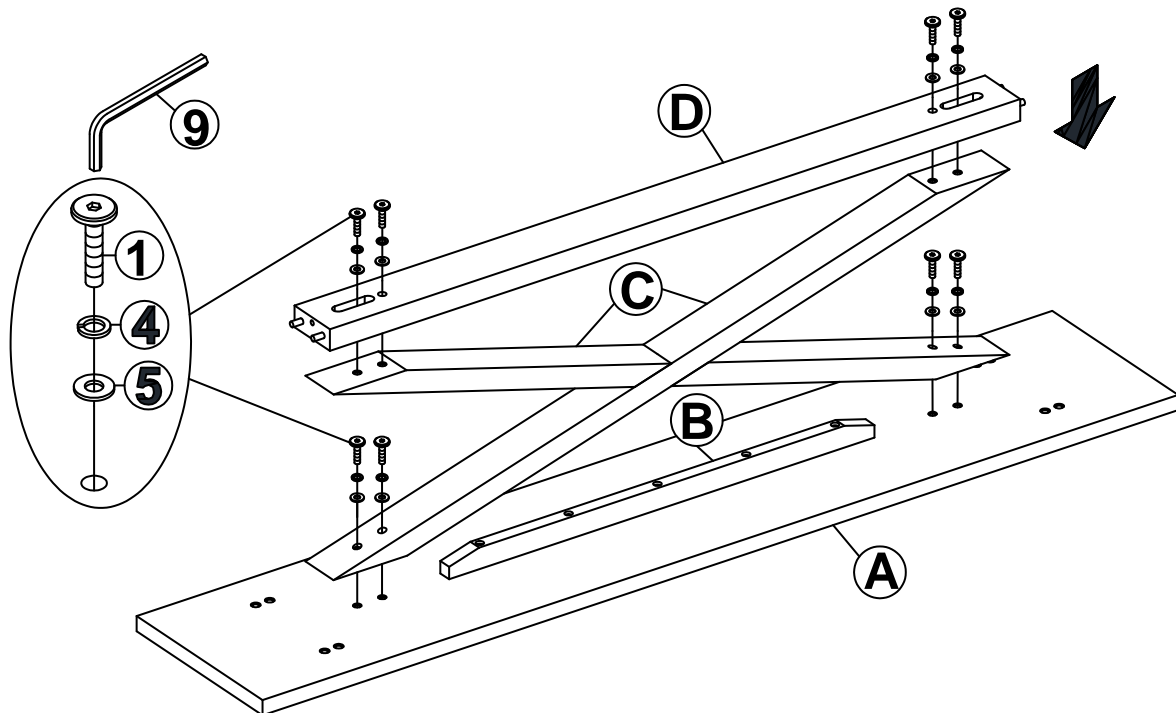

STEP 3

Attach bases (E) to cross bar (D) with bolts (2) and u-washers (8) as shown below. Tighten with Allen key (9). Attach bases (E) to the top (A) with bolts (3), and washers (6) and (7) as shown below. Tighten with Allen key (9).

