

ASSEMBLY INSTRUCTIONS

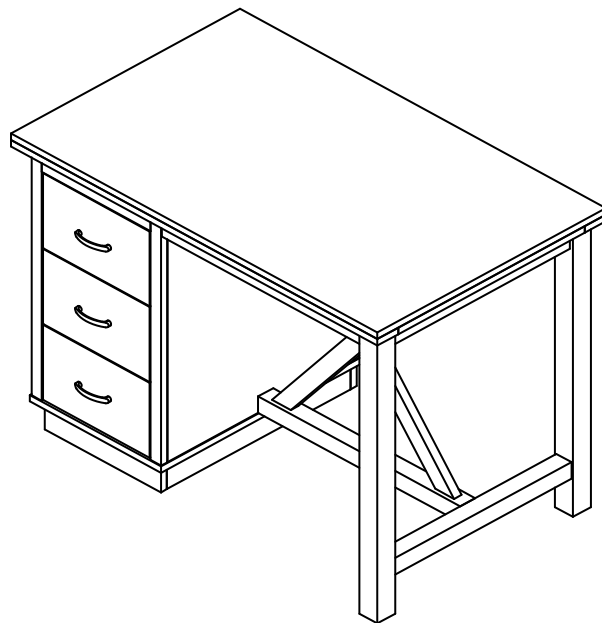
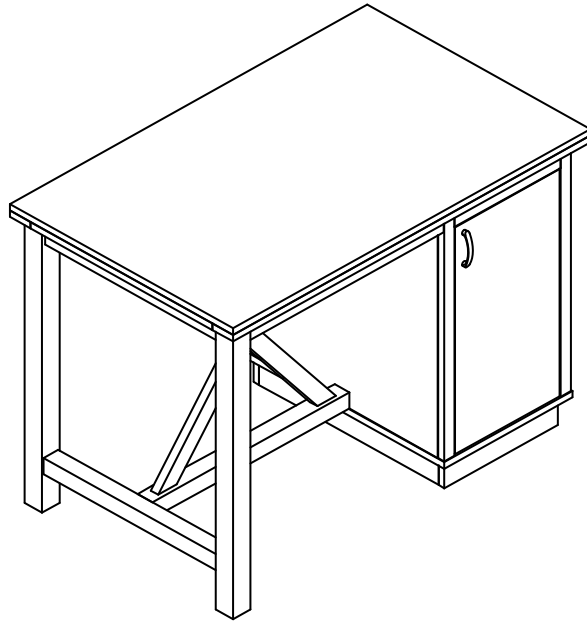

Description	: SINGLE X ISLAND
Item No.	: WC-19A AND WC-19B

BEFORE ASSEMBLY

Thank you for purchasing this quality product. This product has been designed for easy assembly and constructed for durability. All parts were checked prior to packaging to insure quality. Prior to beginning assembly, however, make sure all parts and hardware are included and free of obvious defect. If a part is missing or defective, please contact the store where purchased. If hardware is missing, or you need help with assembly, please call toll free 888-944-8396.

IMPORTANT NOTE:

- Place all wooden parts on a clean and smooth surface such as a rug or carpet to avoid the parts from being scratched.
- Remove all wrapping material, including staples & packing straps before you start to assemble.
- DO NOT tighten all screws and bolts until completely assembled.
- Keep all hardware parts out of reach of children.

WARNING:

Long exposure to rubber or soft plastic may cause a chemical reaction and damage the finish of your product. Protect the surface of the product with cloth if you are using any product with rubber feet or base.



ASSEMBLY TOOLS REQUIRED

NOT INCLUDED

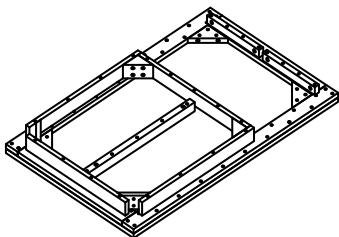

PART LIST WC-19A

When unpacking, please be careful not to discard any parts with the packaging. Before continuing, please make sure you have the following parts:

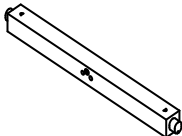
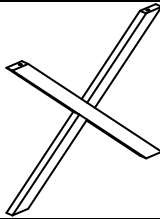
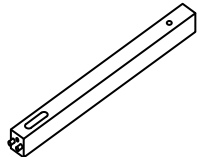
NO	Description	Qty	Sketch	NO	Description	Qty	Sketch
A	Top	1		B	Leg (L-R)	2	
C	Stretcher	1		D	X-frame	1	
E	Cross bar	1					





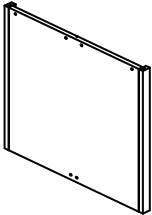
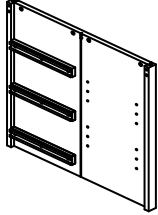
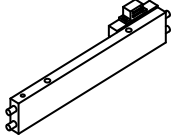
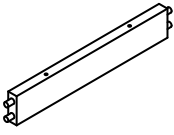
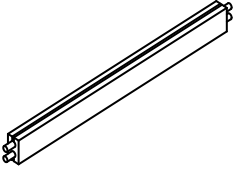
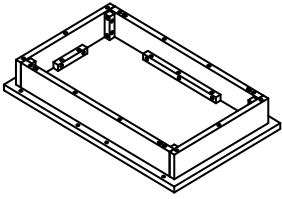
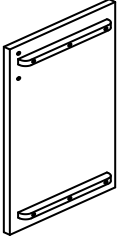
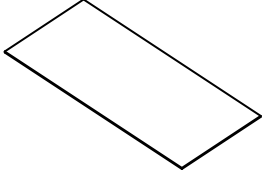
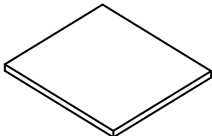
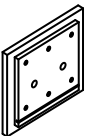
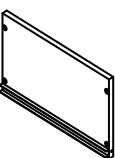
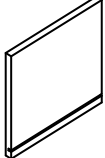
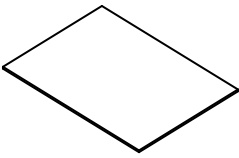





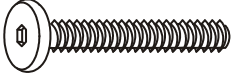

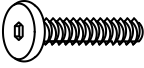
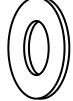
PART LIST WC-19B

When unpacking, please be careful not to discard any parts with the packaging. Before continuing, please make sure you have the following parts:

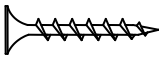
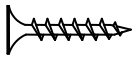
NO	Description	Qty	Sketch	NO	Description	Qty	Sketch
F	Side panel (L)	1		G	Side panel (R)	1	
H	Apron (Front)	1		I	Apron (Back)	1	
J	Apron (Center)	1		K	Bottom	1	
L	Door	1		M	Vertical panel	1	
N	Shelf	2		O	Drawer front	3	
P	Drawer side (L-R)	6		Q	Drawer back	3	
R	Drawer bottom	3					

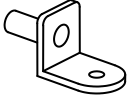
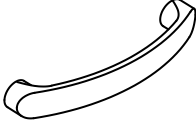
HARDWARE LIST

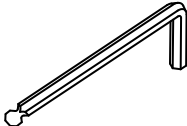
When unpacking, please be careful not to discard any parts with the packaging. Before continuing, please make sure you have all of the following hardware:

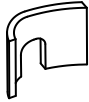
NO	Description	Qty	Sketch	NO	Description	Qty	Sketch
1	Long bolt (M8 x 70mm)	4		2	Medium bolt (M6 x 50mm)	5	
3	Short Bolt (M6 x 35mm)	18		4	Large Flat Washer (φ8.5 x 19mm)	4	
5	Medium Flat Washer (φ6.5 x 16mm)	16		6	Small Flat Washer (φ6.5 x 13mm)	6	
7	Small Lock Washer (φ6.5 x 11mm)	22		8	Large Lock Washer (φ8.5 x 13mm)	4	
9	Long Screw (M4 x 50mm)	6		10	Medium Screw (M4 x 35mm)	24	
11	Short Screw (M3.5 x 15mm)	8		12	Shelf support bracket	8	
13	Handle	4		14	Pan head screw (M4 x 20mm)	8	
15	Allen key (M4 x 30mm x 110mm)	1		16	Door pin (φ5.2/φ13 x 1.2mm) (φ7 x 10mm)	2	
17	U-Washer	1					

NOTE: HARDWARE IS PACKED IN CARTON WC-19B.

ITEM NO.: WC-19A AND WC-19B
REVISED MAY 20, 2019

Printed in Vietnam
THIS ITEM IS PACKED IN TWO CARTONS

STEP 1

Attach legs (B) to the top (A) with bolts (1), and washers (8) and (4) as shown below. Tighten with Allen key (15). Insert stretcher (C) into legs (B) and attach with screws (9) as shown below. Tighten with a screwdriver.

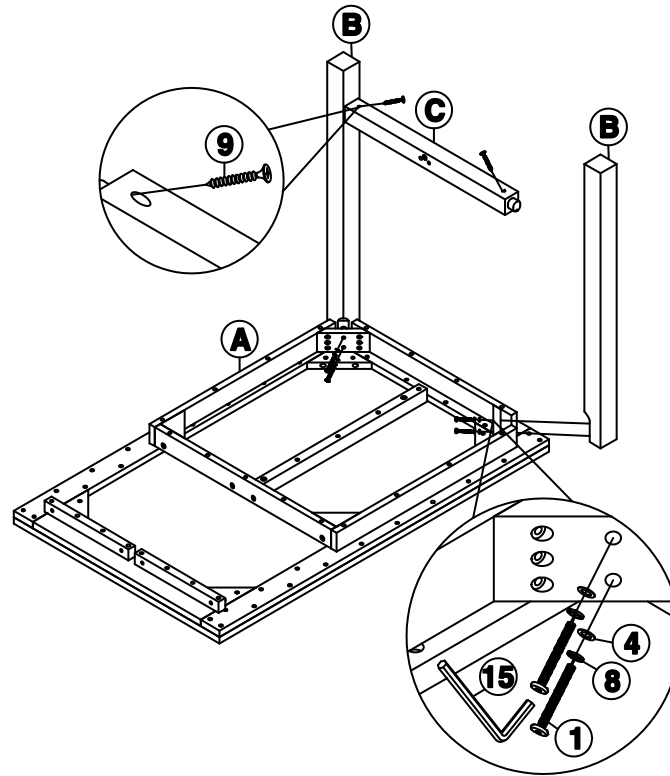

STEP 2

Attach x-frame (D) to the top (A) and crossbar (E) with bolts (2), and washers (7) and (6) as shown below. Tighten with Allen key (15).

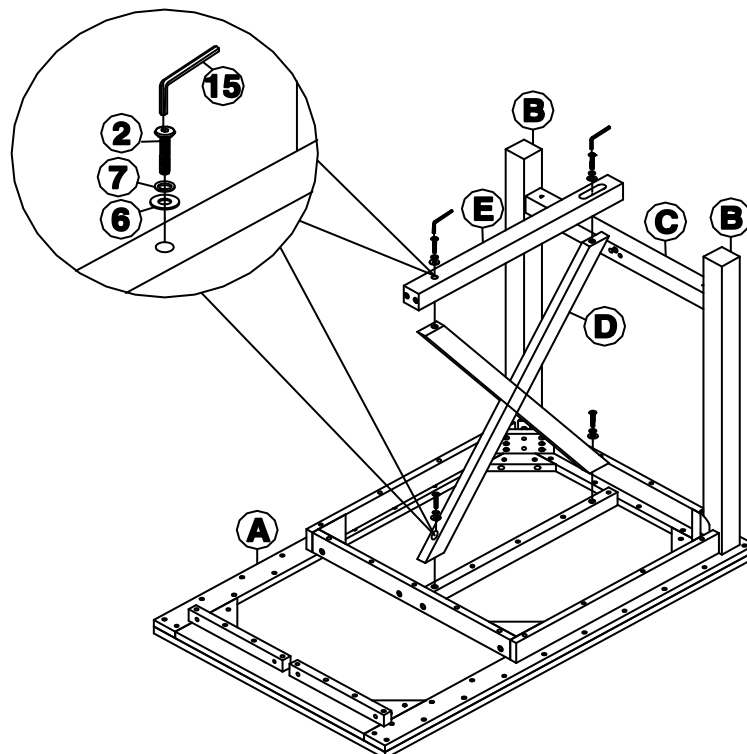

STEP 3

Attach crossbar (E) to stretcher (C) with bolt (2) and u-washer (17) as shown below. Tighten with Allen key (15).

Attach side frame (F) to the top (A) with bolts (3), and washers (7) and (5) as shown below. Tighten with Allen key (15).

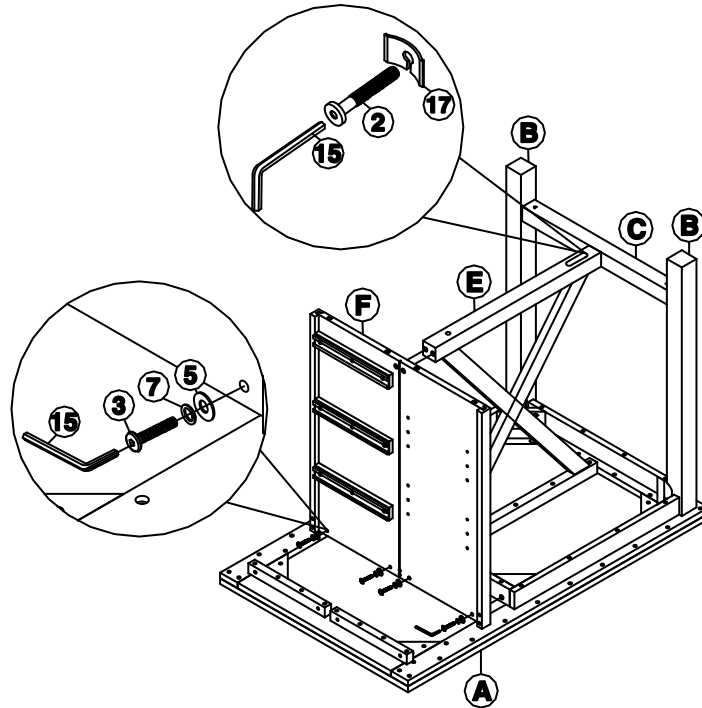

STEP 4

Attach side frame (F) to stretcher (E) with bolts (3), and washers (7) and (6) as shown below. Tighten with Allen key (15).

Insert the aprons (I), (J) and (H) into side frame (F) as shown below.

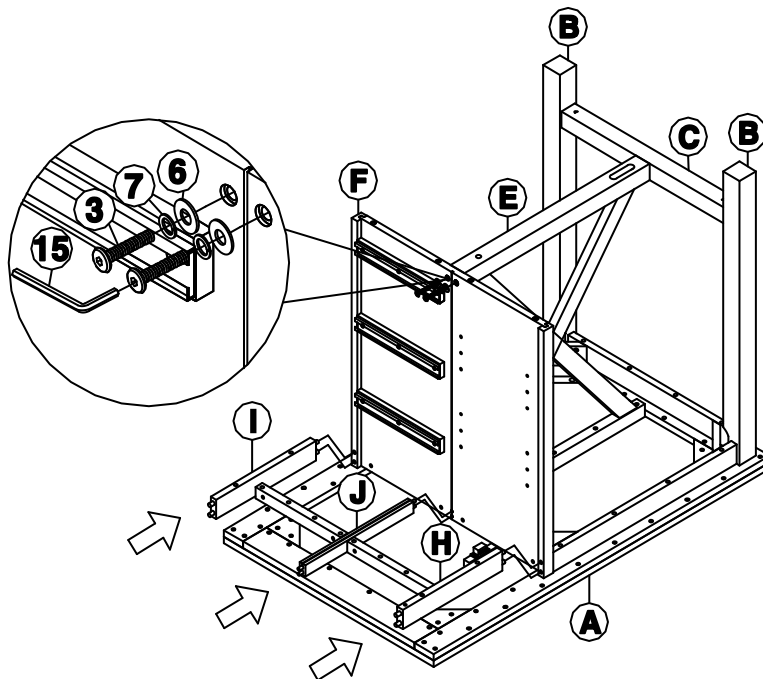

STEP 5

Attach side frame (G) to the unit with bolts (3), and washers (7) and (5) as shown below. Tighten with Allen key (15).

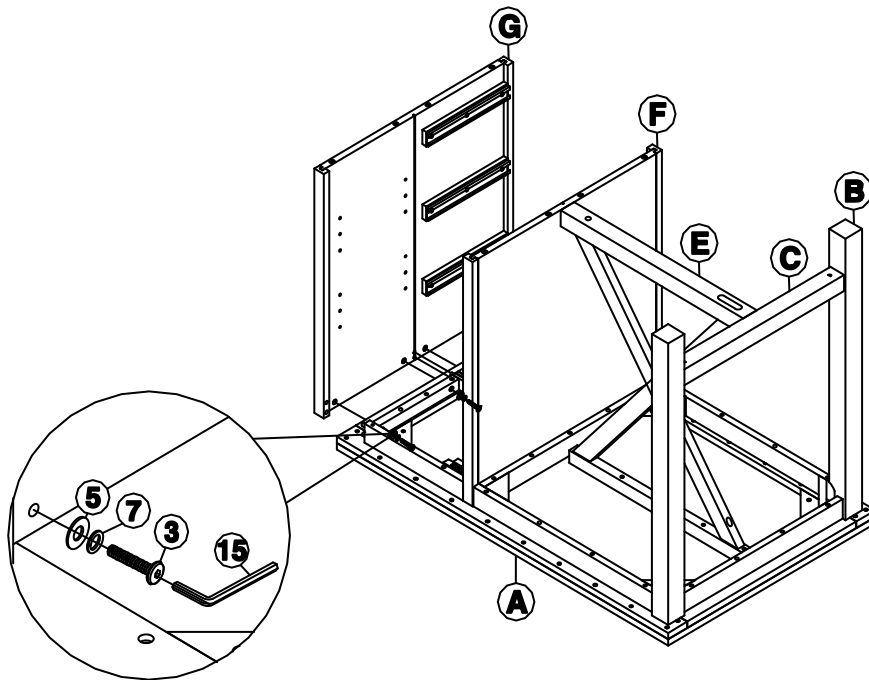

STEP 6

Attach aprons (H) and (I) to the top (A) with screws (9) as shown below. Tighten with a screwdriver. Slide vertical panel (M) into the grooves, as shown below.

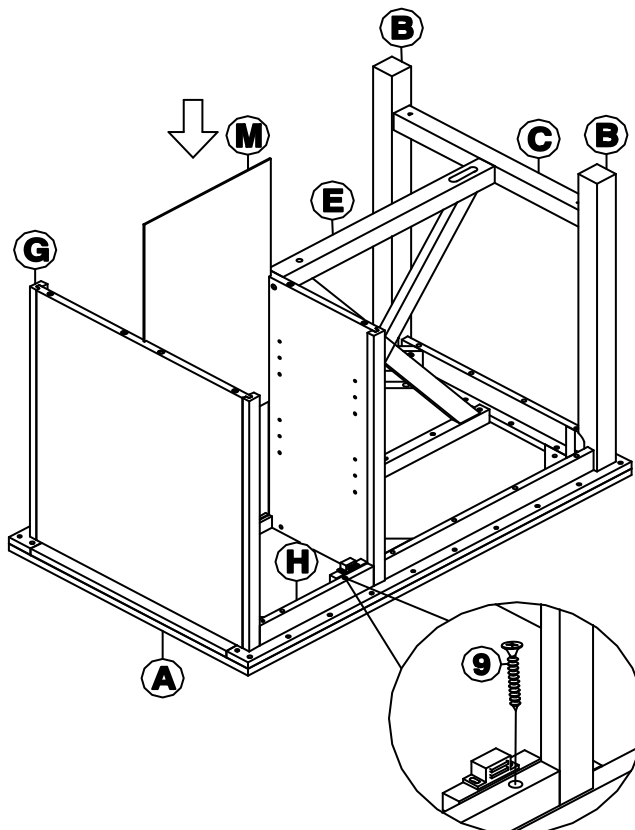

STEP 7

Attach door (L) to top (A) and bottom (K) with door pins (16) as shown below. Then attach bottom (K) to the unit with bolts (3), and washers (7) and (5) as shown below.

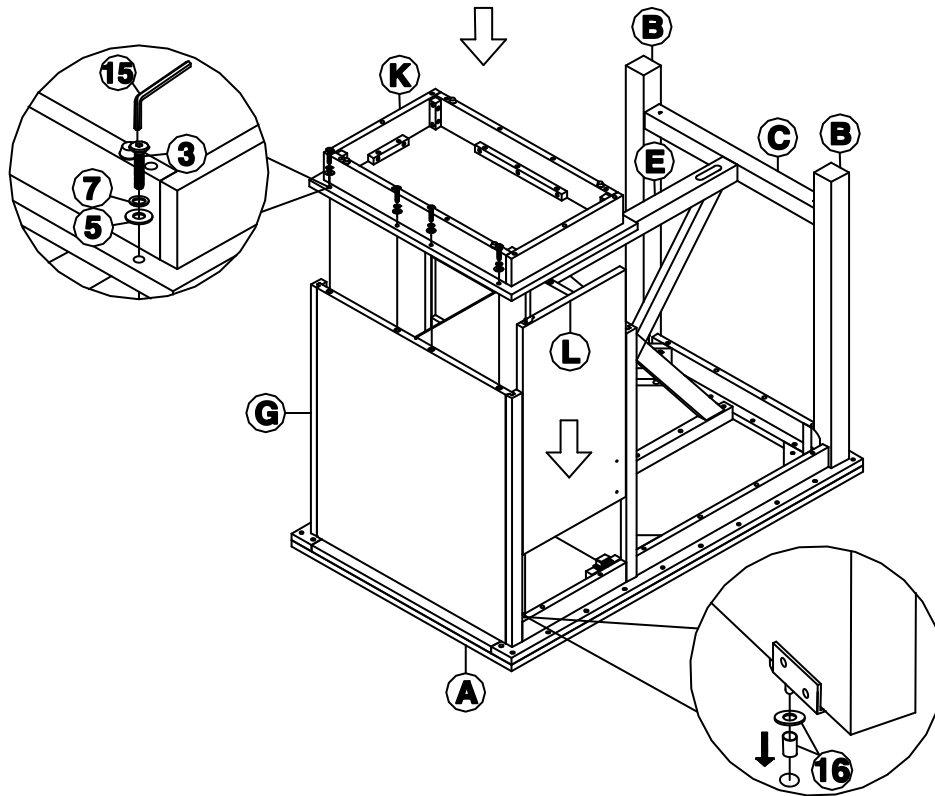

STEP 8

Attach drawer sides (P) to the drawer front (O) with screws (10) as shown below. Tighten with a screwdriver.

Insert drawer bottom (R) into the grooves at bottom of drawer sides (P). Then attach drawer back (Q) to the drawer sides (P) with screws (10). Tighten with a screwdriver.

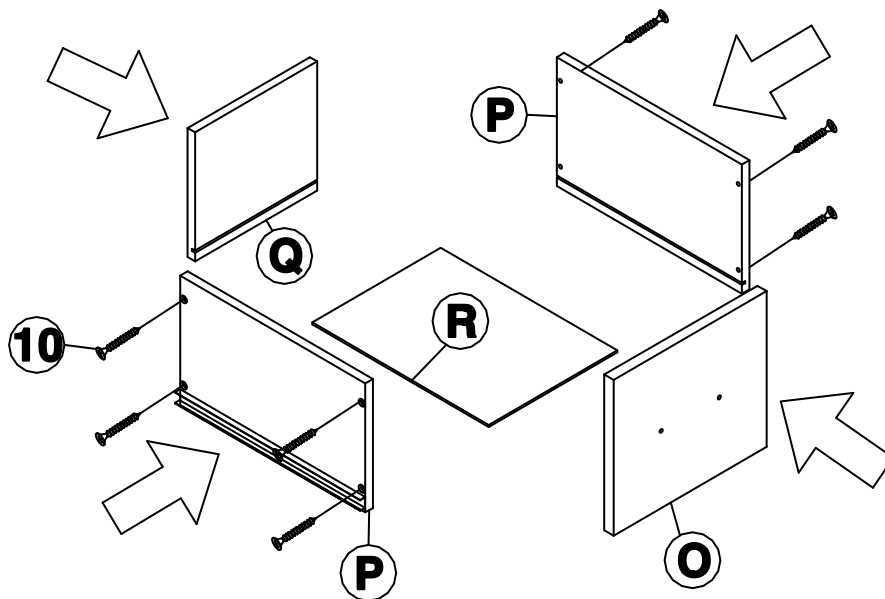

STEP 10

Carefully put the drawers into the unit.

Attach handles (13) to front of doors (L) and drawers with screws (14) as shown below. Tighten with a screwdriver.

Insert brackets (12) into the unit as shown below. Place shelves (N) on the brackets and attach with screws (11). Tighten with a screwdriver.

